

The original ROOTS blower still leads the way™



Exclusive
WHISPAIR™ Design
Reduces Stress,
Vibration and Noise

	J	K	K'	K''	P	P'
01	67.38	54.50	27.25	27.25	71.00	75.00
50	"	"	"	"	74.00	78.00
.01	"	"	"	"	79.00	83.00
5.01	"	"	"	"	81.00	85.00
4.50	"	"	"	"	84.00	88.00
55.75	"	"	"	"	86.50	90.00
56.50	"	"	"	"	88.00	92.00
59.50	77.50	69.00	30.00	39.00	94.00	96.00
60.50	"	"	"	"	"	104.00
64.50	"	"	"	"	"	"

Conventional blowers are buffeted up to 120 times a second with shock waves traveling at the speed of sound. The resulting pulses and vibrations steal power and shorten the life of every bearing, gear and other drive train component.

ROOTS RAS-J air blowers and RGS-J gas blowers have a solution to your problem. ROOTS' exclusive WHISPAIR™ jet design is proven to equalize pressure pulses, reducing shock wave intensity by up to 40%. Here's what this means to you:



Longer bearing life

Less shock transmitted through the impellers means approximately 20% longer bearing life. Other components such as timing gears, drive couplings, v-belts and motor bearings suffer less stress, too.

Lower energy consumption

The patented ROOTS WHISPAIR's jet design precisely meters backflow and channels air pressure in the direction of impeller rotation. The result is an extra "push" that reduces the power required to drive the impellers.

Lower Noise

Pressure pulses are also the major source of blower and gas blower noise. The pressure equalizing effect of the Whispair™ design reduces noise by approximately 5 dBA, while reducing wear on your piping valves and sensitive instrumentation.

Testing

Every Roots blower is mechanically tested to design extremes of speed, pressure and temperature. Roots validates the flow capacity as well as major critical factors such as vibration, oil circulation and operating clearances. This ensure your blower is manufactured to the highest standards with performance proven to meet your process needs. Special testing requirements are welcome.

Cylinder and headplates

All units are configureable to horizontal or vertical flows. Cylinders and headplates are precision machined grey iron, with cast ribs for improved strength and heat transfer. All RAS-J and RGS-J blowers incorporate

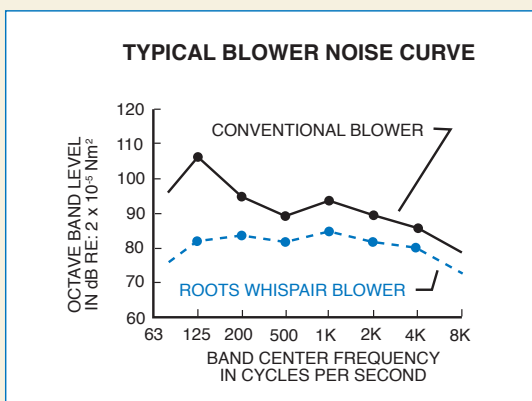
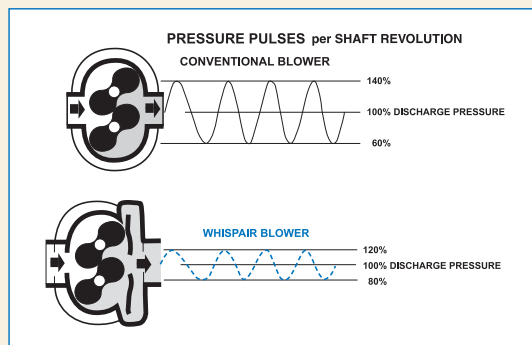

a wrap-around plenum design and feature ROOTS' exclusive WHISPAIR™ jet. Castings may be subjected to strenuous pressure and leak testing to ensure integrity in the most demanding applications.

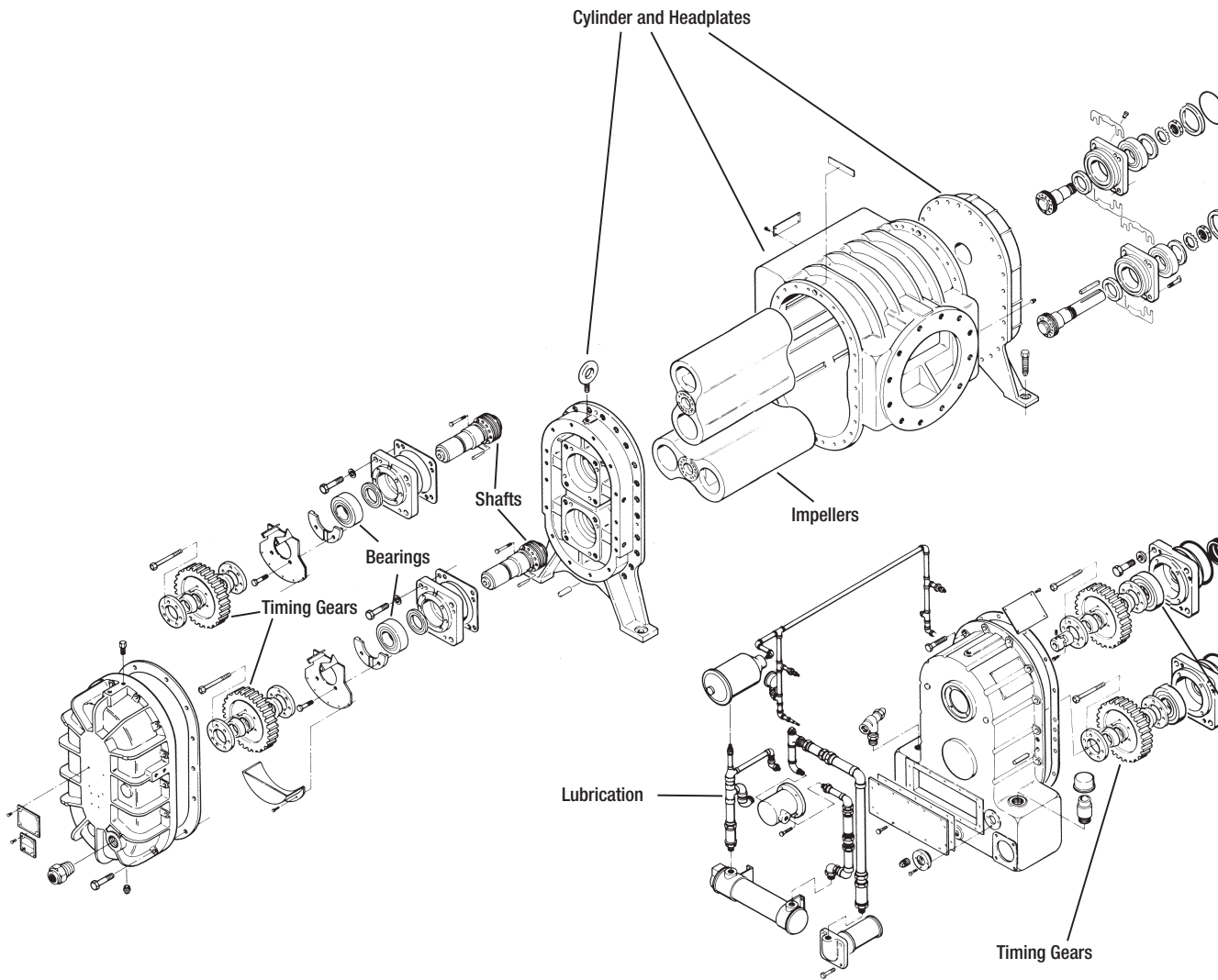

Impellers

Made from ductile iron with a tensile strength of 60,000 PSI, impellers are statically and dynamically balanced to industry accepted standards, providing you with years of trouble free performance and durability.

Shafts

Impeller shafts are alloy steel forgings, flange connected to the impeller bodies with high-tensile socket head capscrews. Standard blowers have precision machined labyrinth seals where the shaft passes the casing headplate. A single piston ring or multiple piston rings may also be employed with various purge gas configurations to meet customer specific requirements.

Bearings

Long-life, double -row spherical roller bearings support the shaft assemblies and control axial location of the impellers at the thrust end. An inboard 5th bearing minimizes drive shaft stress on 1000J through 1400J frame size, V-belt driven blowers and gas blowers.

Timing Gears

The impellers rotation is timed by a pair of precision machined, forged steel gears. These wide-faced spur gears are manufactured to AGMA standards and are carburized and ground with a hardness of 58-60 Rc. Spur gears do not transmit harmful axial loads to bearings and motors.

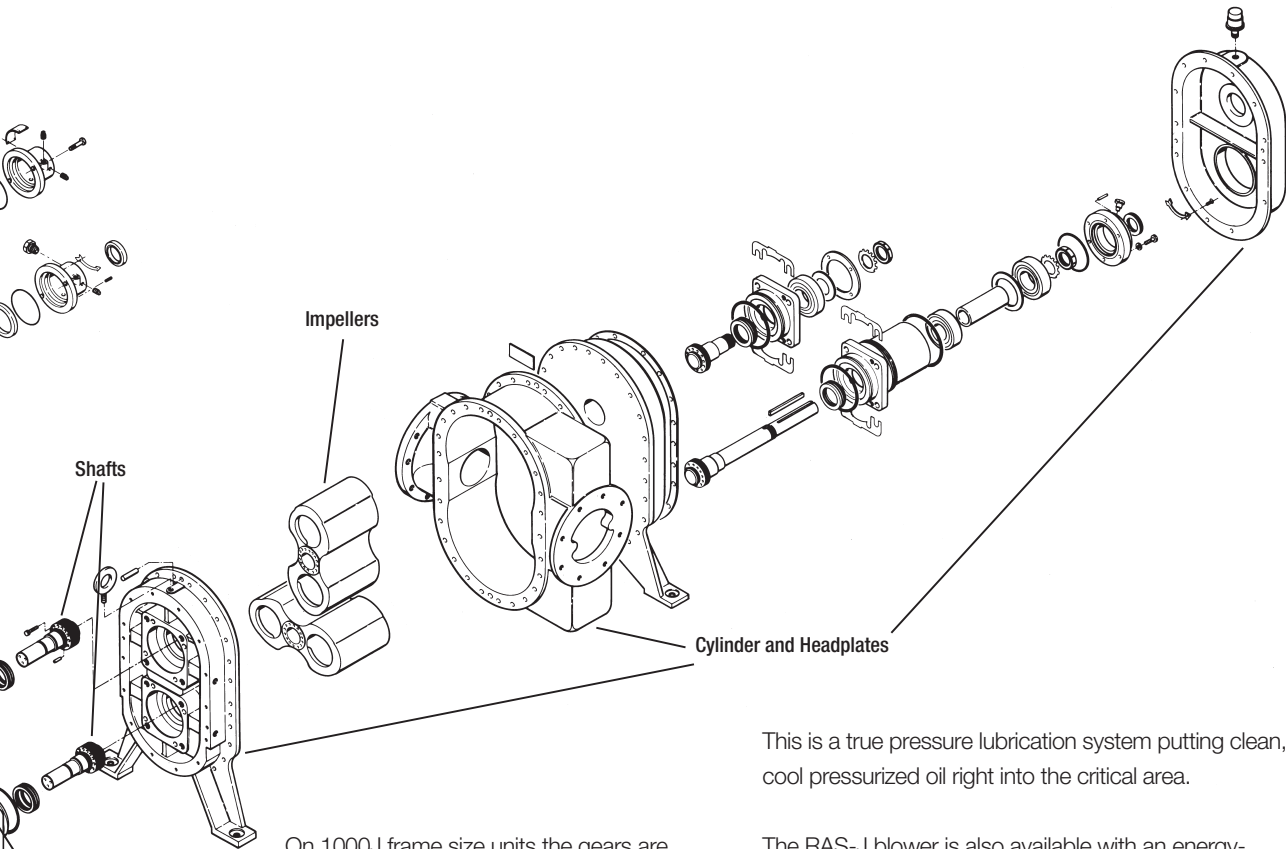

On 1000J frame size units the gears are secured to the shafts by a taper fit. Larger sizes use a proven taper locking device providing an easily adjustable and releasable mechanical shrink fit. No shaft-weakening keyways or locking pins are required.

Lubrication

Both RAS-J blowers and RGS-J blowers offer a positive pressure lubrication system which can extend bearing life by up to 50%. This system is entirely self-contained and includes an integral drive oil pump, distribution piping, gearbox oil sump, filter oil cooler, pressure gauge, relief valve and low oil pressure safety switch.

This is a true pressure lubrication system putting clean, cool pressurized oil right into the critical area.

The RAS-J blower is also available with an energy-saving splash lubrication system in place for the pressure system.

Each unit tested, certified.

Every RAS-J blower and RGS-J gas blower is tested at the factory to guarantee that each unit meets performance specifications. Test procedures include a complete flow test at full speed and pressure, as well as vibration measurement at three different performance levels.

RAS-J Air Blower

Timing gear locking arrangement for 1000J frame sizes

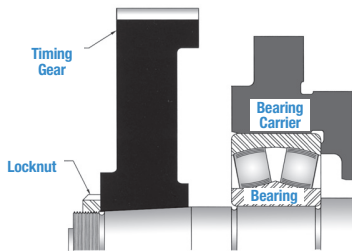

Taper Fit

RAS-J Air Blower

Timing gear locking arrangement for 1200J – 2000J frame sizes

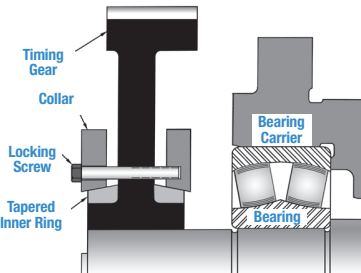

Locking Ring

RGS-J Gas Blower

Detail Mechanical Seal

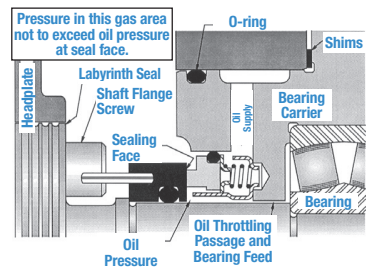

Detail Options

Performance Specifications

FRAME SIZE	SPEED SIZE	4 PSI			6 PSI			8 PSI			10 PSI			12 PSI			15 PSI			18 PSI			MAX. PRESS. PSI	MAX. VAC. HHG	
		CFM	BHP	BHP/G	CFM	BHP	BHP/G	CFM	BHP	BHP/G	CFM	BHP	BHP/G	CFM	BHP	BHP/G	CFM	BHP	BHP/G	CFM	BHP	BHP/G			
1006J	1800	1320	34	39	1285	46	52	1256	59	64	1230	71	89	1206	83	107	1174	102	107	1093	120	126	20.0	16	
1009J	1800	2007	47	52	1961	66	71	1922	84	90	1887	103	108	1856	121	127	1814	149	154	1687	177	182	20.0	16	
1012J	1800	2676	62	67	2615	86	92	2562	111	117	2516	136	141	2475	160	166	2418	197	203	2249	234	240	18.0	16	
1016J	1800	3752	82	88	3680	116	122	3621	150	156	3568	184	190	3519	218	224							13.3	16	
1018J	1800	4266	93	98	4185	131	137	4117	170	175	4057	208	214										11.7	16	
1021J	1800	4781	104	109	4690	147	152	4614	190	196	4546	234	239										10.4	16	
1024J	1800	5461	118	124	5358	167	173	5271	216	222													9.2	16	
1030J	1800	6822	143	148	6692	205	210																7.3	15	
1212J	1500	3238	76	82	3174	106	111	3120	135	141	3072	165	170	3028	194	200	2970	238	244	2796	283	289	20.0	16	
1216J	1500	4354	100	105	4268	139	145	4195	179	185	4130	218	224	4072	258	264	3993	317	323				16.5	16	
1220J	1500	5508	121	127	5418	170	176	5342	220	226	5275	269	275	5214	319	325							13.2	16	
1222J	1500	6193	134	140	6092	190	196	6006	245	251	5931	301	307										11.7	16	
1225J	1500	6892	147	153	6779	209	214	6684	270	276	6600	332	338										10.5	16	
1228J	1500	7857	165	171	7728	236	241	7619	306	312													9.2	16	
1236J	1500	9912	203	209	9749	292	298																7.3	15	
1414J	1300	4680	113	121	4592	155	163	4518	197	206	4453	240	248	4394	262	290	4315	346	354	4243	409	419	20.0	16	
1418J	1300	5976	141	149	5864	195	204	5770	249	258	5687	304	312	5611	358	366	5510	439	448				16.6	16	
1422J	1300	7357	165	173	7243	230	238	7146	296	304	7061	362	370	6985	427	435							13.7	16	
1425J	1300	8184	180	188	8057	253	262	7950	326	335	7855	400	409	7770	472	481							12.2	16	
1428J	1300	9156	199	207	9014	280	289	8894	362	370	8789	444	452										11.0	16	
1431J	1300	10300	220	228	10140	312	320	10005	404	412													9.8	16	
1435J	1300	11455	244	252	11277	346	354	11127	450	457													8.8	16	
1442J	1300	13527	292	300	13327	411	422																7.3	15	
1616J	1130	5879	144	155	5772	197	208	5683	250	261	5604	303	314	5533	356	367	5436	436	447	5349	515	526	20.0	16	
1620J	1130	7343	178	187	7210	244	253	7099	310	320	7000	377	386	6911	442	452	5510	542	553				17.6	16	
1625J	1130	9184	210	220	9018	293	303	8878	376	386	8755	461	469	8644	542	552							14.0	16	
1627J	1130	10049	224	235	9900	314	324	9774	403	414	9663	493	503	9563	582	593							13.0	16	
1630J	1130	11162	245	255	10996	344	355	10856	444	454	10733	543	554										11.7	16	
1633J	1130	12275	266	276	12093	375	386	11939	485	495	11804	594	604										10.6	16	
1638J	1130	14511	310	320	14296	439	449	14114	568	579													9.0	16	
1643J	1130	15959	339	350	15758	482	492	15558	624	635													8.2	16	
1648J	1130	17861	378	389	17596	538	549																7.3	15	
1821J	1000	8658	206	216	8507	284	294	8380	362	372	8288	440	450	8166	518	528	8029	635	654	7905	752	762	18.8	16	
1824J	1000	9902	233	242	9729	322	332	9584	411	421	9455	500	510	9311	589	599	9182	723	734				16.5	16	
1827J	1000	11127	260	270	10933	360	370	10769	460	470	10625	560	570	10464	661	671							14.6	16	
1830J	1000	12521	286	296	12341	397	407	12190	509	519	12056	620	630	11893	731	741							13.2	16	
1833J	1000	13978	313	323	13777	437	447	13608	562	571	13455	686	696										11.7	16	
1838J	1000	15858	347	357	15630	488	498	15439	630	639	15270	771	780										10.4	16	
1841J	1000	17108	370	379	16863	522	532	16656	674	684													9.5	16	
1845J	1000	18781	400	410	18512	567	577	18285	734	744													8.8	16	
1849J	1000	20454	433	441	20161	615	623	19914	797	805													8.0	16	
1854J	1000	22541	474	484	22218	675	685																	7.3	15

Performance Specifications

FRAME SIZE	SPEED SIZE	4 PSI			6 PSI			8 PSI			10 PSI			12 PSI			15 PSI			18 PSI			MAX. VAC HHG	MAX. PRESS. PSI
		CFM	BHP	BHP/G	CFM	BHP	BHP/G	CFM	BHP	BHP/G	CFM	BHP	BHP/G	CFM	BHP	BHP/G	CFM	BHP	BHP/G	CFM	BHP	BHP/G		
2022J	900	10357	244	255	10191	337	348	10051	429	441	9927	522	533	9816	615	626	9664	754	765	9528	893	904	19.6	16
2026J	900	12197	283	294	12001	392	403	11836	501	512	11691	611	622	11550	720	731	11381	884	895				16.6	16
2033J	900	15606	342	353	15400	480	491	15226	618	629	15073	756	767	14930	894	905							13.0	16
2037J	900	17468	376	387	17237	530	541	17042	685	696	16870	839	851										11.7	16
2040J	900	18632	397	408	18386	562	573	18178	727	738	17995	892	903										11.0	16
2044J	900	20494	431	442	20223	613	624	19994	794	805	19793	975	987										10.0	16
2047J	900	21894	456	467	21604	650	661	21360	844	855													9.4	16
2050J	900	23290	482	493	22982	688	699	22723	894	905													8.8	16
2055J	900	25619	529	540	25280	756	767																7.9	16
2057J	900	25552	548	558	26200	783	793																7.7	15
2060J	900	27948	574	585	27579	822	833																7.3	15
2062J	900	28880	583	603	28498	849	859																7.0	14
2064J	900	29807	612	622	29412	876	886																6.9	14

Ratings based on inlet air at standard temperature of 68°F, ambient pressure of 14.7 psia and specific gravity of 1.0
 Note: BHP/G is the brake horsepower for the mechanically sealed RGS-J blower.

Performance Specifications (RAS-J Forty PSL)

FRAME SIZE	SPEED SIZE	4 PSI			6 PSI			8 PSI			10 PSI			12 PSI			15 PSI			18 PSI			20 PSI			22 PSI		
		CFM	BHP	BHP/G	CFM	BHP	BHP/G	CFM	BHP	BHP/G	CFM	BHP	BHP/G	CFM	BHP	BHP/G	CFM	BHP	BHP/G	CFM	BHP	BHP/G	CFM	BHP	BHP/G	CFM	BHP	BHP/G
2022	900	10357	244	258	10191	337	351	10051	430	444	9827	523	537	9816	615	629	9664	755	769	9528	894	908	9443	966	1000	9362	1079	1093
2026	900	12197	283	297	12001	393	407	11836	502	516	11691	611	625	11559	720	734	11381	884	898	11220	1048	1062	11120	1157	1171	11025	1267	1281
2030	900	13974	313	327	13789	437	451	13634	561	575	13496	694	698	13372	808	822	13204	994	1008	13052	1179	1193						
2033	900	15606	342	356	15400	480	494	15226	618	632	15073	757	771	14834	895	909	14746	1102	1116	14577	1309	1323						
2037	900	17468	376	390	17237	531	545	17042	685	699	16870	840	854	16715	995	1009	16505	1226	1240	16315	1458	1472						
2040	900	18632	398	412	18386	563	577	18178	728	742	17995	882	906	17830	1057	1071	17606	1305	1319	17403	1552	1566						
2044	900	20494	432	446	20223	613	627	19994	794	808	19793	976	990	19611	1157	1171	19365	1429	1443	19142	1701	1715						
2047	900	21896	458	472	21607	651	665	21362	845	859	21147	1039	1053	20953	1233	1247	20690	1524	1538									
2050	900	23290	482	496	22982	688	702	22723	894	908	22494	1101	1115	22287	1307	1321	22007	1616	1630									
2055	900	25619	529	543	25280	756	770	24985	983	997	24743	1210	1224	24516	1437	1451												
2057	900	26554	548	562	26203	783	797	25907	1018	1032	25646	1253	1267	25411	1488	1502												
2060	900	27948	575	589	27579	822	836	27267	1070	1084	26993	1317	1331	26745	1564	1578												
2062	900	28883	592	606	28501	848	862	28179	1104	1118	27896	1359	1373	27639	1615	1629												
2064	900	28810	610	624	28415	874	888	28083	1137	1151	28790	1401	1415	28526	1665	1679												
2070	900	32606	662	676	32175	951	965	31812	1240	1254	31491	1528	1542															
2072	900	33541	680	694	33088	977	991	32724	1274	1288	32394	1571	1585															
2080	900	37264	751	765	36771	1081	1095	36356	1411	1425	35990	1740	1754															

Dimensions

FRAME SIZE	PRESSURE LUBE							SPLASH LUBE								
	HORIZONTAL FLOW		VERTICAL FLOW		BOTH		MAX WGT.	HORIZONTAL FLOW		VERTICAL FLOW		BOTH		MAX WGT.	INLET	DISCH.
	O	P	O	P	C	C'		O	P	O	P	C	C'			
1006J	34.75	28.50	28.75	36.00	39.56	48.44	2000	34.75	28.50	28.75	30.75	30.50	39.38	1940	6	6
1009J	34.75	28.50	28.75	36.00	42.56	51.44	2110	34.75	28.50	28.75	30.75	33.50	42.38	2050	10	8
1012J	34.75	28.50	28.75	36.00	45.56	54.44	2280	34.75	28.50	28.75	30.75	36.50	45.38	2200	10	8
1016J	34.88	28.50	28.75	36.00	50.56	58.94	2510	34.88	28.50	28.75	30.75	41.00	49.88	2400	12	10
1018J	34.88	28.50	28.75	36.00	52.31	61.19	2590	34.88	28.50	28.75	30.75	43.25	52.13	2450	12	10
1021J	34.88	28.50	28.75	36.00	54.56	63.44	2690	34.88	28.50	28.75	30.75	45.50	54.38	2550	14	12
1024J	34.88	28.50	28.75	36.00	57.56	66.44	3110	34.88	28.50	28.75	30.75	48.50	57.38	3000	14	12
1030J	34.88	28.50	28.75	36.00	63.56	72.44	3660	34.88	28.50	28.75	30.75	45.50	63.38	3500	16	14
1212J	40.50	33.30	33.13	40.00	46.56	49.88	3165	40.50	33.00	33.13	36.75	40.06	44.38	3100	12	10
1216J	40.50	33.30	33.13	40.00	49.56	53.88	3575	40.50	33.00	33.13	36.75	44.06	48.38	3400	14	12
1220J	40.50	33.30	33.13	40.00	53.56	57.88	3790	40.50	33.00	33.13	36.75	48.06	52.38	3650	16	14
1222J	40.50	33.30	33.13	40.00	56.06	60.38	3990	40.50	33.00	33.13	36.75	50.56	54.38	3800	16	14
1225J	40.50	33.30	33.13	40.00	58.56	62.88	4185	40.50	33.00	33.13	36.75	53.06	57.38	4000	16	14
1228J	40.50	33.30	33.13	40.00	62.06	66.38	4345	40.50	33.00	33.13	36.75	56.56	60.88	4150	18	16
1236J	40.50	33.30	33.13	40.00	69.56	73.88	4875	40.50	33.00	33.13	36.75	64.06	68.38	4650	20	18
1414J	47.25	38.50	38.00	45.25	53.38	59.19	4820	47.25	38.50	38.00	43.00	45.13	50.94	4600	14	12
1418J	47.25	38.50	38.00	45.25	57.38	63.19	5130	47.25	38.50	38.00	43.00	49.13	54.94	4900	14	12
1422J	47.25	38.50	38.00	45.25	61.38	67.19	5460	47.25	38.50	38.00	43.00	53.13	58.94	5200	16	14
1425J	47.25	38.50	38.00	45.25	63.38	69.69	5700	47.25	38.50	38.00	43.00	55.63	61.44	5300	18	16
1428J	47.25	38.50	38.00	45.25	66.38	72.69	5950	47.25	38.50	38.00	43.00	58.63	64.44	5650	18	16
1431J	47.25	38.50	38.00	45.25	70.38	76.19	6220	47.25	38.50	38.00	43.00	62.13	67.94	5900	18	16
1435J	47.25	38.50	38.00	45.25	73.38	79.69	6500	47.25	38.50	38.00	43.00	65.53	71.44	6200	20	18
1442J	47.25	38.50	38.00	45.25	80.88	86.69	7090	47.25	38.50	38.00	43.00	72.63	78.44	6750	24	20

Table continued on next page

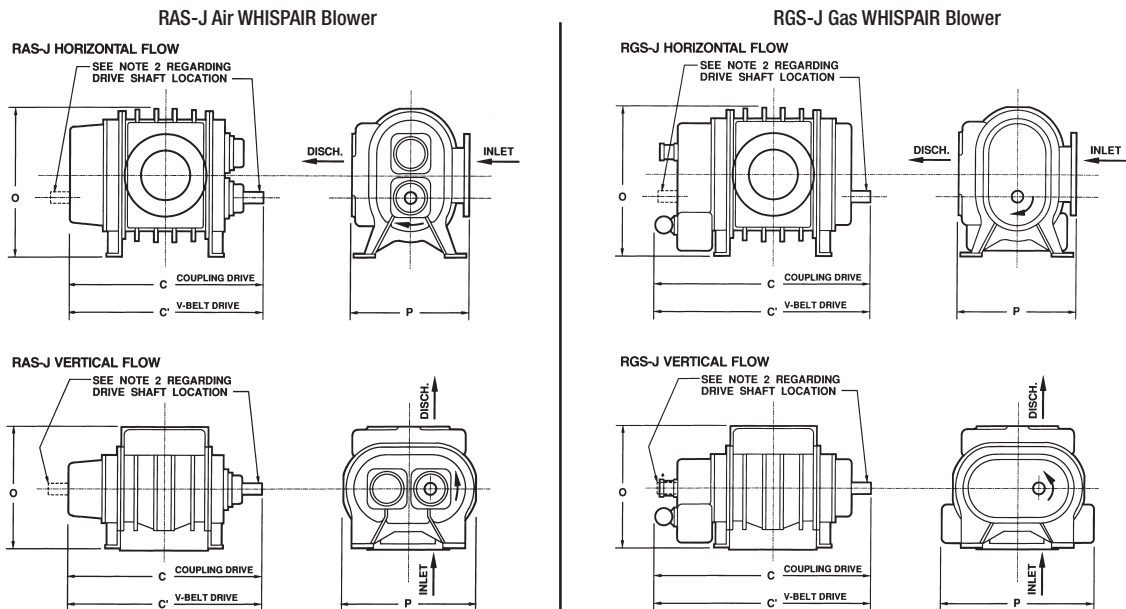

Dimensions

FRAME SIZE	PRESSURE LUBE							SPLASH LUBE								
	HORIZONTAL FLOW		VERTICAL FLOW		BOTH		MAX WGT.	HORIZONTAL FLOW		VERTICAL FLOW		BOTH		MAX WGT.	INLET	DISCH.
	O	P	O	P	C	C'		O	P	O	P	C	C'			
1616J	53.75	44.50	43.25	51.00	48.31	—	6185	53.75	44.50	43.25	49.50	48.31	—	5700	14	12
1620J	53.75	44.50	43.25	51.00	52.31	—	6465	53.75	44.50	43.25	49.50	52.31	—	6000	16	14
1625J	53.75	44.50	43.25	51.00	57.31	—	6800	53.75	44.50	43.25	49.50	57.31	—	6300	20	18
1627J	53.75	44.50	43.25	51.00	59.31	—	7135	53.75	44.50	43.25	49.50	59.31	—	6600	20	18
1630J	53.75	44.50	43.25	51.00	62.31	—	7480	53.75	44.50	43.25	49.50	62.31	—	6850	20	18
1633J	53.75	44.50	43.25	51.00	65.31	—	7830	53.75	44.50	43.25	49.50	65.31	—	7250	24	20
1639J	53.75	44.50	43.25	51.00	71.31	—	8370	53.75	44.50	43.25	49.50	71.31	—	7800	24	20
1643J	53.75	44.50	43.25	51.00	75.31	—	8580	53.75	44.50	43.25	49.50	75.31	—	8000	30	24
1648J	53.75	44.50	43.25	51.00	80.31	—	8790	53.75	44.50	43.25	49.50	80.31	—	8200	30	24
1821J	59.25	49.50	48.00	56.00	57.31	—	8440	59.25	49.50	48.00	54.00	57.31	—	7800	18	16
1824J	59.25	49.50	48.00	56.00	57.31	—	8770	59.25	49.50	48.00	54.00	60.31	—	8100	20	16
1827J	59.25	49.50	48.00	56.00	57.31	—	9190	59.25	49.50	48.00	54.00	63.31	—	8400	20	16
1830J	59.25	49.50	48.00	56.00	57.31	—	9610	59.25	49.50	48.00	54.00	66.31	—	8850	24	20
1833J	59.25	49.50	48.00	56.00	57.31	—	10030	59.25	49.50	48.00	54.00	69.31	—	9300	24	20
1838J	59.25	49.50	48.00	56.00	57.31	—	10300	59.25	49.50	48.00	54.00	74.31	—	9600	24	20
1841J	59.25	49.50	48.00	56.00	57.31	—	10450	59.25	49.50	48.00	54.00	77.31	—	9750	30	24
1845J	59.25	49.50	48.00	56.00	57.31	—	10870	59.25	49.50	48.00	54.00	81.31	—	10100	30	24
1849J	59.25	49.50	48.00	56.00	57.31	—	11170	59.25	49.50	48.00	54.00	85.31	—	10400	30	26
1854J	59.25	49.50	48.00	56.00	57.31	—	11470	59.25	49.50	48.00	54.00	90.31	—	10650	30	26
2022J	66.13	54.50	52.75	61.25	61.13	—	10660	66.13	54.50	52.75	61.25	61.13	—	9800	20	16
2026J	66.13	54.50	52.75	61.25	65.13	—	11120	66.13	54.50	52.75	61.25	65.13	—	10250	20	18
2033J	66.13	54.50	52.75	61.25	72.13	—	12130	66.13	54.50	52.75	61.25	72.13	—	11200	24	20
2037J	66.13	54.50	52.75	61.25	76.13	—	13130	66.13	54.50	52.75	61.25	76.13	—	11800	30	24
2040J	66.13	54.50	52.75	61.25	78.63	—	13630	66.13	54.50	52.75	61.25	78.63	—	12450	30	24
2047J	66.13	54.50	52.75	61.25	85.63	—	13900	66.13	54.50	52.75	61.25	85.63	—	12800	30	24
2050J	66.13	54.50	52.75	61.25	88.63	—	14130	66.13	54.50	52.75	61.25	88.63	—	13100	30	24
2057J	66.13	54.50	52.75	61.25	95.63	—	14500	66.13	54.50	52.75	61.25	95.63	—	13450	30	24
2060J	66.13	54.50	52.75	61.25	98.63	—	14850	66.13	54.50	52.75	61.25	98.63	—	13800	30	26
2062J	66.13	54.50	52.75	61.25	100.63	—	15000	66.13	54.50	52.75	61.25	100.63	—	14000	30	26
2064J	66.13	54.50	52.75	61.25	102.63	—	15300	66.13	54.50	52.75	61.25	102.63	—	14300	30	26

Dimensions (RAS-J Forty PSL)

FRAME SIZE	PRESSURE LUBE					SPLASH LUBE						
	HORIZONTAL FLOW		BOTH		MAX WGT.	HORIZONTAL FLOW		BOTH		MAX WGT.	INLET	DISCH.
	O	P	C	C'		O	P	C	C'			
2047	67.38	54.50	94.38	31.50	14820	67.38	54.50	94.38	31.50	14820	30	24
2050	67.38	54.50	97.38	33.00	15000	67.38	54.50	97.38	33.00	15000	30	26
2055	67.38	54.50	102.38	35.50	15300	67.38	54.50	102.38	35.50	15300	36	30
2057	67.38	54.50	104.38	36.50	15450	67.38	54.50	104.38	36.50	15450	36	30
2060	67.38	54.50	107.38	38.00	15750	67.38	54.50	107.38	38.00	15750	36	30
2062	67.38	54.50	109.88	39.25	16250	67.38	54.50	109.88	39.25	16250	36	30
2064	67.38	54.50	111.38	40.00	16750	67.38	54.50	111.38	40.00	16750	36	30
2070	77.50	69.00	117.38	43.00	20750	77.50	69.00	117.38	43.00	20750	42	42
2072	77.50	69.00	119.38	44.00	21000	77.50	69.00	119.38	44.00	21000	42	42
2080	77.50	69.00	127.38	48.00	23000	77.50	69.00	127.38	48.00	23000	42	42

Contact Dresser Roots for details on other available blower sizes.

Application Engineering

Roots may have the largest & most experienced product support network in the industry. Around the world, we have an office or a service center where you need it. Dresser Roots supports your business by delivering products and services designed, built and delivered to perform in your unique process environment. We have the desire to work with you and develop a detailed solution configured to meet and, ideally to exceed your requirements. Roots has been “the quiet leader” in the blower business since 1854 providing long-lasting performance in the worlds toughest applications.

Global Presence

- 55 Distributors with 95 locations in North and South America
- 35 Agents and Reps locations in North America
- Direct Sales Offices located in Asia, Europe, South America and North America
- 4 Authorized Distributors in China
- 2 Authorized Distributors in Australia
- 2 Authorized Distributors India
- 1 each Authorized Distributors in Saudi Arabia, Egypt, South Africa, Thailand, Pakistan, Japan, Taiwan, Philippines, Malaysia, New Zealand, South Korea, U.A.E, Turkey and Kuwait.
- 1 each Authorized Distributors in Major EU countries except France, Switzerland and Belgium

Service

Seven (7) Factory Authorized and Trained Service Centers

- Houston, Texas
- Connersville, Indiana
- Mexico City, Mexico
- Skelmersdale, UK
- Dubai, U.A.E
- Shanghai, China



About Dresser Roots

Dresser Roots, a major product brand of Dresser, Inc., is the manufacturer of the original ROOTS™ blower, centrifugal compressors and control systems. ROOTS® air and gas moving equipment is used in a wide variety of applications, including MVR (Mechanical Vapor ecompression), water and wastewater treatment, flue gas desulphurization, petrochemical and chemical processes, conveying, and other general industrial applications.

About Dresser, Inc.

Dresser, Inc. is a leader in providing highly engineered infrastructure products for the global energy industry. The company has leading positions in a broad portfolio of products, including valves, actuators, meters, switches, regulators, piping products, natural gas-fueled engines, retail fuel dispensers and associated retail point-of-sale systems, and air and gas handling equipment. Leading brand names within the Dresser portfolio include Dresser Wayne® retail fueling systems, Waukesha® natural gas-fired engines, Masoneilan® control valves, Consolidated® pressure relief valves, and Roots® blowers. It has manufacturing and customer service facilities located strategically worldwide and a sales presence in more than 100 countries.

Dresser Roots

Houston, Texas Headquarters • U.S. Toll Free Phone: 1 877-363-ROOT(S) (7668) • Direct Phone: +1 832-590-2600

Connersville, Indiana Operations • U.S. Toll Free Phone: 1 877-442-7910 • Direct Phone: +1 765-827-9285

European Operations • Phone: +44 (0) 1695 52600 • Email: roots.europe@dresser.com

USA/Canada Sales • Phone: +1 773-444-3360

Houston, Texas Factory Service • Phone: +1 713-896-4810

Mexico City Sales and Factory Service • Phone: +52 55 5889 5811

Dubai Sales and Factory Service • Phone: +971 4-8855481

Malaysia Sales • Phone: +60 3 2267 2600

China Sales • Phone: +86 10 8486 2440

Shanghai Factory Service • Phone: +86 21 5858 7638

©2010 Dresser, Inc. All rights reserved. • Printed in the U.S.A. • All information subject to change without notice. • Roots, Wayne, Waukesha, Masoneilan and Consolidated are registered trademarks of Dresser, Inc. • ROOTS and WHISPAIR, are trademarks of Dresser, Inc.

B-5219 rev. 0410



www.dresserroots.com/