

Engineered
Packages

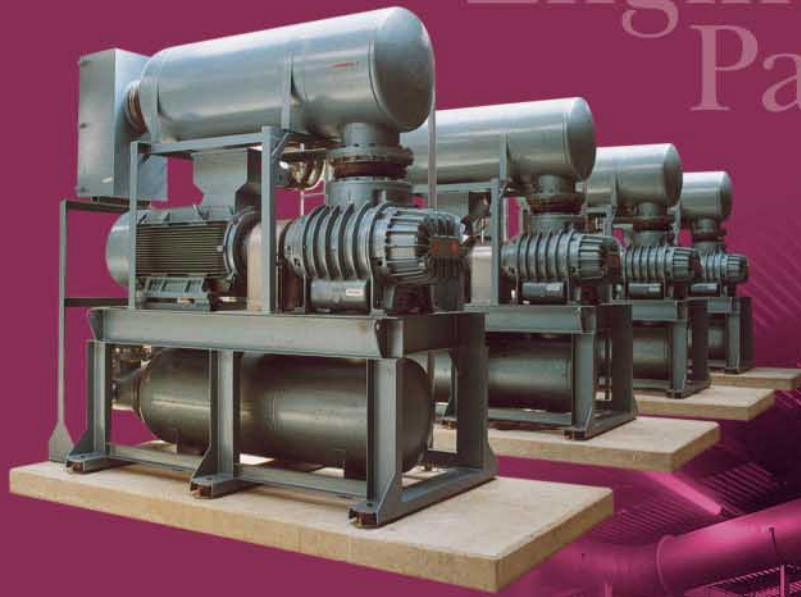

Roots Packaged Blower Units

Standard
Packages



ROOTS Blowers & Vacuum Pumps

DRESSER

Standard Blower and Exhaust

SRB/SRE Series

SRB blower units and SRE exhauster units Each standard packaged blower or exhauster combines a Roots blower unit supplying oil-free air with an electric motor, vee-belt drive, intake filter/silencer, filter restriction indicator, discharge silencer, non return valves and relief valves. The blower is mounted on a rigid baseplate and contained within a practical acoustic enclosure, which reduces radiated noise levels for noise sensitive locations.

The SRB range covers pressures from 300 to 1000 mbar (1.5-15kW) with inlet volumes from 50m³/h to 300m³/h. The SRE range covers 300 mbar to 500 mbar (1.5kW to 7.5kW). Pressure relief and non-return valves are supplied loose for installation into customer's pipework. Both packages have hinged access with security locks.



MRB blower units The MRB range of standard package units offer pressures from 300 mbar to 1000 mbar (7.5kW to 30kW) and inlet volumes from 400m³/h to 1400m³/h.

Each MRB package combines a Roots URAI blower unit supplying oil free air with an electric motor, vee-belt drive, intake filter/silencer, discharge silencer, filter restriction indicator, non return valve and pressure relief valve. The blower is mounted on a rigid baseplate with fork-lift slots and contained within a fan vented acoustic enclosure, which reduces radiated noise levels for noise sensitive locations.

The pressure relief valve and non-return valve are supplied loose for installation into customer's pipework. The package has hinged access with security locks.

MRE exhauster units The MRE offers vacuums from 200 mbar to 500 mbar (5.5kW to 30kW) with all the features of the MRB.

All packages comply with the EU machinery directive with regard to CE marking.

MRB/MRE Range



At the heart of the SRB/E and MRB/E Package

Reliability is at the heart of every package in the form of the DRESSER Roots Universal RAI® blower/exhauster. The URAI is designed, precision machined and built using the latest computer aided methods. This ensures close tolerances between the impellers, casing and headplates to minimise back slippage of air and improve both efficiency and reliability. The DRESSER Roots exclusive "Figure of 8" gearbox design improves oil distribution and lengthens bearing and gear life. Oversize anti-friction bearings support the shafts. On the drive end, cylindrical roller bearings carry vee-belt side loading and extend service life.

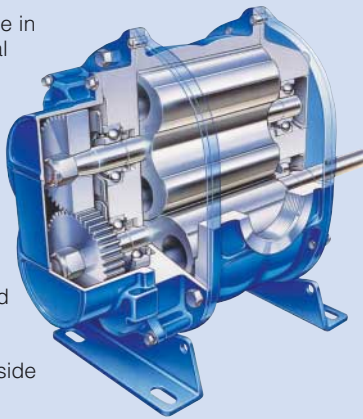

dimensions

SRB BLOWER UNIT

	L	W	H
	mm	mm	mm
A Pack	800	600	725
B Pack	1100	950	850

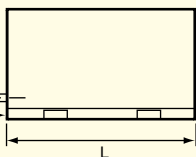
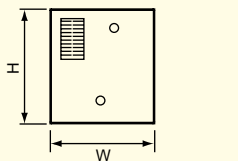

Channels for lifting with forklift truck

SRE EXHAUSTER UNIT

	L	W	H
	mm	mm	mm
A Pack	800	600	725
B Pack	1100	950	850

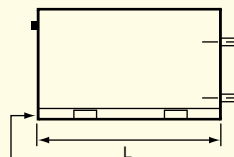
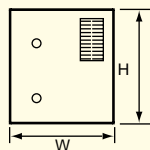

Channels for lifting with forklift truck

MRB BLOWER UNIT

	L	W	H
	mm	mm	mm
	1300	1100	1100

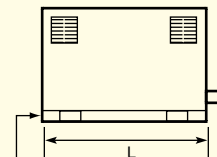
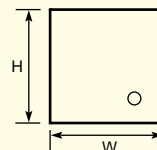

Channels for lifting with forklift truck

MRE EXHAUSTER UNIT

	L	W	H
	mm	mm	mm
	1300	1100	1100

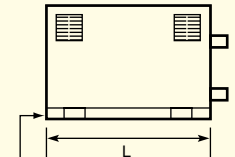
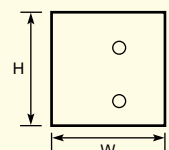

Channels for lifting with forklift truck

ter Packages

performance data

Blower Units	Operating pressure mbar	Air volumes at 1013 mbar a and 20 °C		Motor size kW	Weight Kg	Pack size
		m ³ /hr	cfm			
SRB 3002	300	20	12	1.5	199	A
SRB 3005	300	50	29	1.5	199	A
SRB 3010	300	100	59	2.2	201	A
SRB 3015	300	150	88	3.0	215	A
SRB 3020	300	200	118	3.0	332	B
SRB 3025	300	250	147	4.0	361	B
SRB 3030	300	300	177	5.5	386	B
SRB 4002	400	20	12	1.5	199	A
SRB 4005	400	50	29	1.5	199	A
SRB 4010	400	100	59	2.2	201	A
SRB 4015	400	150	88	4.0	227	A
SRB 4020	400	200	118	4.0	344	B
SRB 4025	400	250	147	5.5	386	B
SRB 4030	400	300	177	7.5	389	B
SRB 5002	500	20	12	1.5	199	A
SRB 5005	500	50	29	2.2	201	A
SRB 5010	500	100	59	3.0	209	A
SRB 5015	500	150	88	4.0	242	A
SRB 5020	500	200	118	5.5	386	B
SRB 5025	500	250	147	7.5	389	B
SRB 5030	500	300	177	7.5	396	B
SRB 6002	600	20	12	1.5	199	A
SRB 6005	600	50	29	2.2	201	A
SRB 6010	600	100	59	4.0	221	A
SRB 6015	600	150	88	5.5	384	B
SRB 6020	600	200	118	7.5	387	B
SRB 6025	600	250	147	7.5	389	B
SRB 6030	600	300	177	11.0	464	B
SRB 7005	700	50	29	3.0	209	A
SRB 7010	700	100	59	5.5	384	B
SRB 7015	700	150	88	5.5	384	B
SRB 7020	700	200	118	7.5	387	B
SRB 7025	700	250	147	11.0	457	B
SRB 7028	700	280	165	11.0	457	B
SRB 8007	800	70	41	4.0	221	A
SRB 8010	800	100	59	5.5	384	B
SRB 8015	800	150	88	7.5	387	B
SRB 8020	800	200	118	11.0	455	B
SRB 8025	800	250	147	11.0	457	B
SRB 8028	800	280	165	11.0	464	B
SRB 9013	900	130	77	7.5	387	B
SRB 9015	900	150	88	7.5	387	B
SRB 9020	900	200	118	11.0	464	B
SRB 9025	900	250	147	11.0	464	B
SRB 9028	900	280	165	15.0	466	B
SRB 10018	1000	180	106	11.0	455	B
SRB 10020	1000	200	118	11.0	464	B
SRB 10025	1000	250	147	15.0	466	B
SRB 10027	1000	270	159	15.0	466	B

Ratings are ± 4% based on inlet air at temperature of 20 deg C, inlet pressure of 1013 mbarA and RH of 0%.

MRB 3040	300	400	235	7.5	380
MRB 3045	300	450	265	7.5	380
MRB 3050	300	500	294	7.5	380
MRB 3055	300	550	324	7.5	395
MRB 3060	300	600	353	7.5	570
MRB 3065	300	650	383	11	570
MRB 3070	300	700	412	11	570
MRB 3080	300	800	471	11	570
MRB 3090	300	900	530	11	620
MRB 3100	300	1000	589	15	620
MRB 4035	400	350	206	7.5	380
MRB 4040	400	400	235	11	425
MRB 4045	400	450	265	11	425
MRB 4050	400	500	294	11	425
MRB 4055	400	550	324	11	448
MRB 4060	400	600	353	11	570
MRB 4065	400	650	383	15	570
MRB 4075	400	750	441	15	570
MRB 4085	400	850	500	15	620
MRB 4100	400	1000	589	18.5	650
MRB 4110	400	1100	647	18.5	650
MRB 4125	400	1250	736	22	700
MRB 4130	400	1300	765	22	700
MRB 4135	400	1350	793	22	700
MRB 4140	400	1400	823	30	785
MRB 5040	500	400	235	11	570
MRB 5045	500	450	265	11	570
MRB 5050	500	500	294	11	570
MRB 5055	500	550	324	15	570
MRB 5060	500	600	353	15	570
MRB 5065	500	650	383	15	570
MRB 5070	500	700	412	15	570
MRB 5075	500	750	441	18.5	590

Blower Units	Operating pressure mbar	Air volumes at 1013 mbar a and 20 °C		Motor size kW	Weight Kg	Pack size
		m ³ /hr	cfm			
MRB 5080	500	800	471	18.5	590	
MRB 5085	500	850	500	18.5	640	
MRB 5090	500	900	530	18.5	640	
MRB 5100	500	1000	589	22	700	
MRB 5105	500	1050	618	30	790	
MRB 5120	500	1200	706	30	790	
MRB 5130	500	1300	765	30	790	
MRB 6040	600	400	235	11	570	
MRB 6045	600	450	265	15	570	
MRB 6050	600	500	294	15	570	
MRB 6055	600	550	324	15	570	
MRB 6060	600	600	353	15	620	
MRB 6070	600	700	412	18.5	620	
MRB 6075	600	750	441	22	620	
MRB 6080	600	800	471	22	620	
MRB 6085	600	850	500	22	620	
MRB 6090	600	900	530	22	620	
MRB 7045	700	450	265	15	570	
MRB 7060	700	600	353	18.5	590	
MRB 7070	700	700	412	22	690	
MRB 7085	700	850	500	30	770	
MRB 8040	800	400	235	15	580	
MRB 8045	800	450	265	18.5	600	
MRB 8050	800	500	294	18.5	600	
MRB 9040	900	400	235	18.5	600	
MRB 9045	900	450	265	18.5	600	
MRB 9050	900	500	294	22	650	
MRB 10040	1000	400	235	18.5	600	
MRB 10045	1000	450	264	22	650	
MRB 10050	1000	500	294	22	650	

Ratings based on inlet air at temperature of 20 deg C, inlet pressure of 1013 mbarA and RH of 0%.

Exhauster Units	Vacuum mbar	Air volumes at 1013 mbar a and 20 °C		Motor size kW	Weight Kg	Pack size
		m ³ /hr	cfm			
SRE 202	200	20	12	1.5	208	A
SRE 205	200	50	29	1.5	208	A
SRE 210	200	100	59	1.5	208	A
SRE 215	200	150	88	2.2	220	A
SRE 220	200	200	118	2.2	220	A
SRE 225	200	250	147	3.0	364	B
SRE 230	200	300	177	3.0	364	B
SRE 302	300	20	12	1.5	208	A
SRE 305	300	50	29	1.5	208	A
SRE 310	300	100	59	2.2	210	A
SRE 315	300	150	88	2.2	220	A
SRE 320	300	200	118	3.0	228	A
SRE 325	300	250	147	4.0	376	B
SRE 330	300	300	177	5.5	401	B
SRE 403	400	30	18	1.5	208	A
SRE 405	400	50	29	1.5	208	A
SRE 410	400	100	59	3.0	228	A
SRE 415	400	150	88	4.0	240	A
SRE 420	400	200	118	4.0	240	A
SRE 425	400	250	147	5.5	401	B
SRE 513	500	130	77	4.0	240	A
SRE 515	500	150	88	4.0	240	A
SRE 520	500	200	118	5.5	405	B
SRE 525	500	250	147	7.5	405	B

Ratings are ± 4% based on inlet air at temperature of 20 deg C, inlet pressure of 1013 mbarA and RH of 0%.

MRE 240	200	400	235	5.5	560
MRE 260	200	600	353	5.5	570
MRE 280	200	800	471	7.5	570
MRE 2100	200	1000	589	11	640
MRE 2120	200	1200	706	15	640
MRE 2140	200	1400	824	15	640
MRE 340	300	400	235	7.5	560
MRE 360	300	600	353	11	570
MRE 380	300	800	471	11	570
MRE 3100	300	1000	589	15	640
MRE 3120	300	1200	706	18.5	650
MRE 435	400	350	206	7.5	560
MRE 455	400	550	324	11	570
MRE 470	400	700	412	15	570
MRE 4100	400	1000	589	18.5	650
MRE 4120	400	1200	706	22	700
MRE 4130	400	1300	765	22	700
MRE 530	500	300	176	7.5	510
MRE 550	500	500	294	15	570
MRE 570	500	700	412	18.5	570
MRE 585	500	850	500	22	700
MRE 5100	500	1000	589	30	780
MRE 5115	500	1150	677	30	780
MRE 5130	500	1300	765	30	780

Ratings based on inlet air at temperature of 20 deg C, inlet pressure of 1013 mbarA and RH of 0%.

Other models available on request

Standard Blower and Exhaust



Extra Low Pulse Units The PRIME package unit range features **five** different standard designs. All PIME packages can be supplied with easy access enclosures for noise sensitive locations.

As a guide, individual package noise levels are between 70 and 85 dBA at 1 metre from the package perimeter in free-field conditions, depending on site conditions.

Please contact our sales department for noise levels at specific operating conditions or to discuss noise requirements.

All packages comply with EU machinery directive with regard to CE marking.

All PRIME units are supported by a full manufacturer's warranty and sales and service support is available from the DRESSER Roots Huddersfield facility in the UK and from our worldwide after-market support network.

All PRIME units are designed to be user friendly and to demonstrate the following key features:

- Extremely compact design
- Short installation cycle time
- Easy maintenance access
- Low installation cost
- Low operation costs

Due to the increased use of common components and a standardised design concept, the PRIME range of package units are available on short lead times.

XLP Prime Range



The Roots XLP Advantage

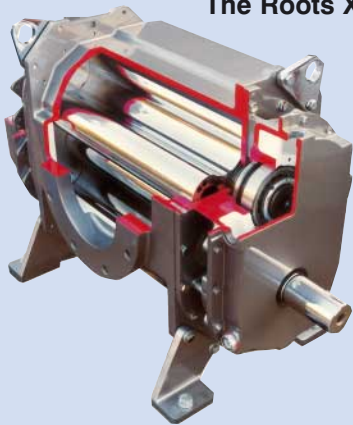

The XLP Whispair® blower is designed to reduce noise and power loss by utilising an exclusive wrap-around plenum and proprietary double* jet Whispair® feature to control pressure equalisation and increase reliability.

The proven design concepts of the 3 lobe impeller profile together with the double jet Whispair® feature, combine to produce such low pulsation levels that inlet and discharge silencers are no longer required to control in-pipe noise and pulsation. This in turn allows for an extremely compact and cost competitive package unit design.

* XLP N08 and N10 have a single jet design.

dimensions

Enclosure Size	Dimensions (mm)					
	L	W1	W2	H1	H2	Z
MRN	1300	1100	1100	1100	1100	Lift off lid†
N	1800	1400	1700	1900	1750	800*
A	2100	1500	1940	2000	1780	950*
B	2600	1700	2200	2700	2450	1200*
C	3000	1400	2500	2900	2650	1350*
D	Refer to factory					

† Removable Panels
* 2 doors each side

PRIME PACKS

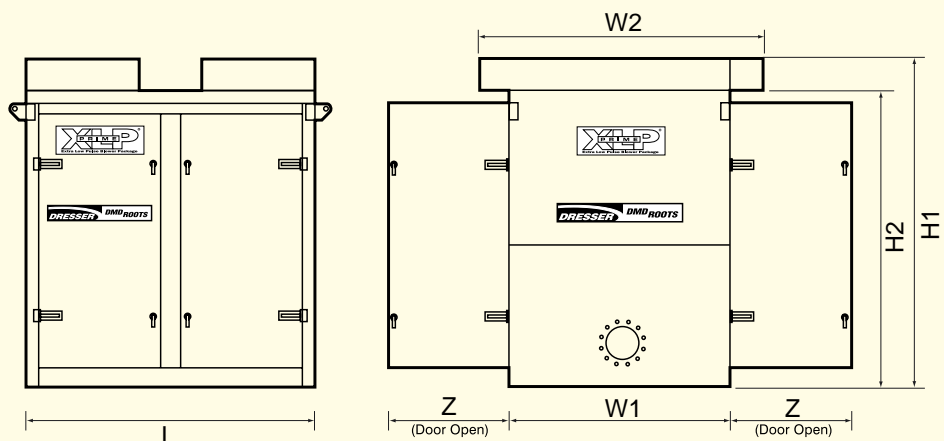

Conventional Packages

In addition to the standard package units supplied in the pre-designed enclosures, conventional packages are available for all blower and vacuum pump models. A full range of ancillaries and acoustic enclosures are available.

All packages comply with EU machinery directive with regard to CE marking.

Acoustic Enclosures A range of acoustic enclosures to match the various sizes of packaged units can be supplied. These are close fitting and are constructed from a range of bolted panels which are manufactured from galvanised sheet steel lined with a layer of sound absorbent material.

Assembling the panels is extremely simple enabling the enclosure to be speedily built up on site. Access doors and sound attenuating ducts for ventilating air are incorporated. The enclosure can be made fully weather-proof if required.

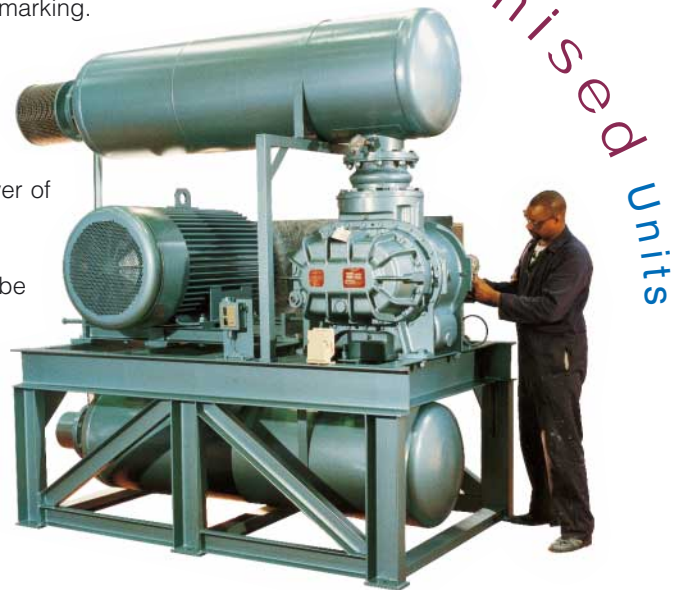

Customised Units

Ancillary Equipment

Electric Motor: An electric motor of sufficient power to drive the blower/ exhauster at the specified duty is fitted.

V-Belt Drive: A wedge belt drive arrangement consisting of pulleys, taper bushes and V-belts is supplied.

Guard: A guard designed to cover the drive is fitted.

Inlet Filter / Silencer: An inlet filter combined with an absorptive or reactive type silencer is fitted to the intake of the blower.

Discharge Silencer: A specially designed silencer is fitted to the discharge of a blower or exhauster. This dissipates pulsation energy and reduces pipeline noise levels.

Filter Restriction Indicator: A restriction indicator to give visual indication of blockage of the inlet filter is fitted.

Pressure Operated Electrical Switch: A pressure or vacuum operated electrical switch designed to stop the machine in the event of an excessive pressure developing on the outlet of the blower, or vacuum at the inlet of an exhauster, can be fitted as an option.

Non-Return Valve: A non-return valve is fitted in the discharge line of a blower or in the suction line of an exhauster to prevent reversal of rotation.

Relief Valve: A relief valve is fitted in the discharge line of a blower or the suction line of an exhauster. This is capable of passing the whole of the volume delivered at the operating speed of the blower.

Flexible Connection: A flexible connection to prevent vibration and shock from reaching downstream equipment is supplied.

Anti-Vibration Mountings: Anti-Vibration mountings capable of isolating both high and low frequencies from foundations can be supplied as an option.

Pressure and Vacuum Gauges: Should a visual indication of pressure be required, pressure and vacuum gauges can be supplied as options.

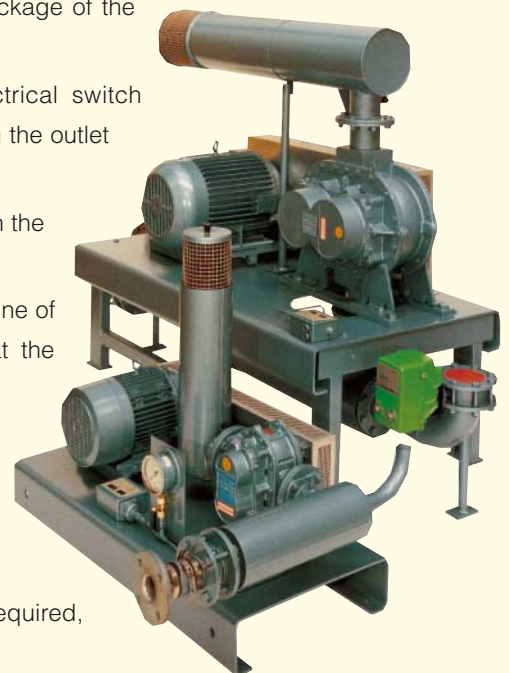

Engineered Packages

DRESSER Roots offer fully engineered packaged blower units designed to meet customer requirements. Pre-assembled skid-mounted packages, with all piping, valves and instrumentation in place are produced for pressure or vacuum applications allowing for simple on-site installation.

▼
A two-stage DVJ dry vacuum pump package for non-cryogenic air separation by VSA (Vacuum Swing Adsorption).

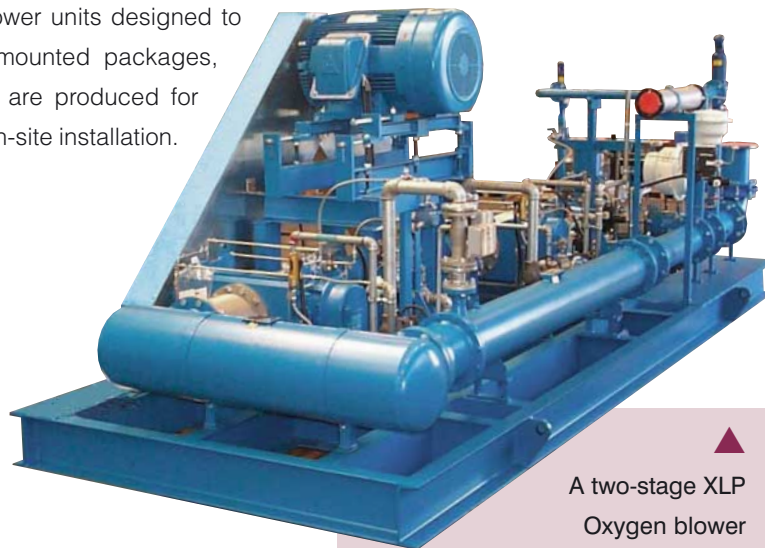

▲
A two-stage XLP Oxygen blower package.

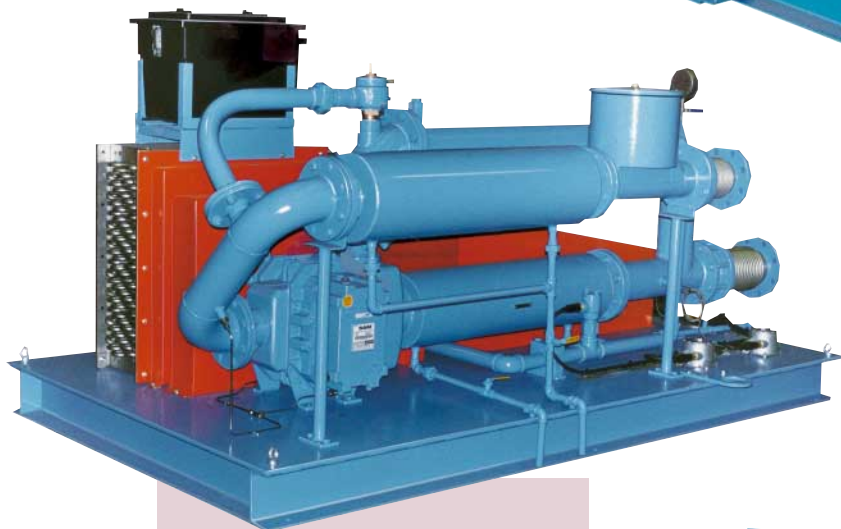
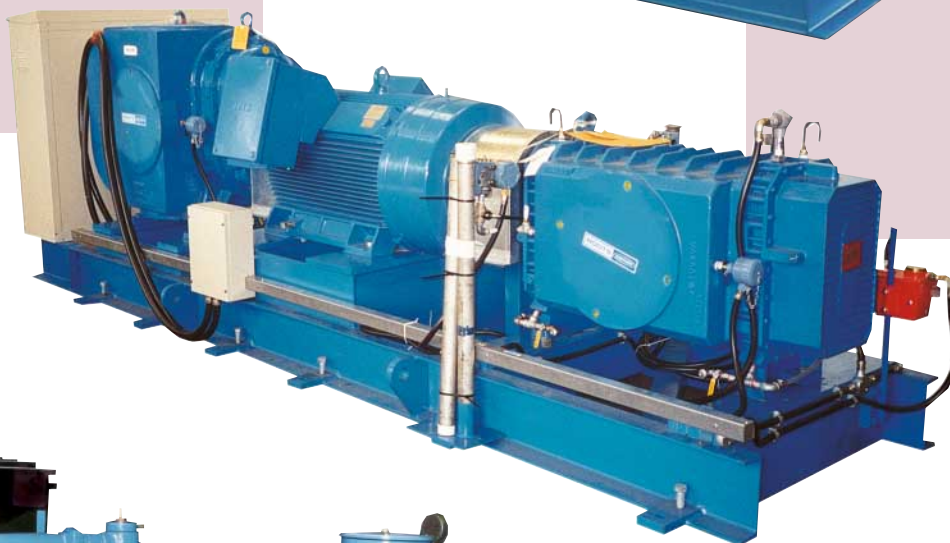

▲
RAM 406-G-DPJ high pressure gas blower for digester gas applications.

▼
This two-stage VJ vacuum pump package is employed on VSA (Vacuum Swing Adsorption) duty.

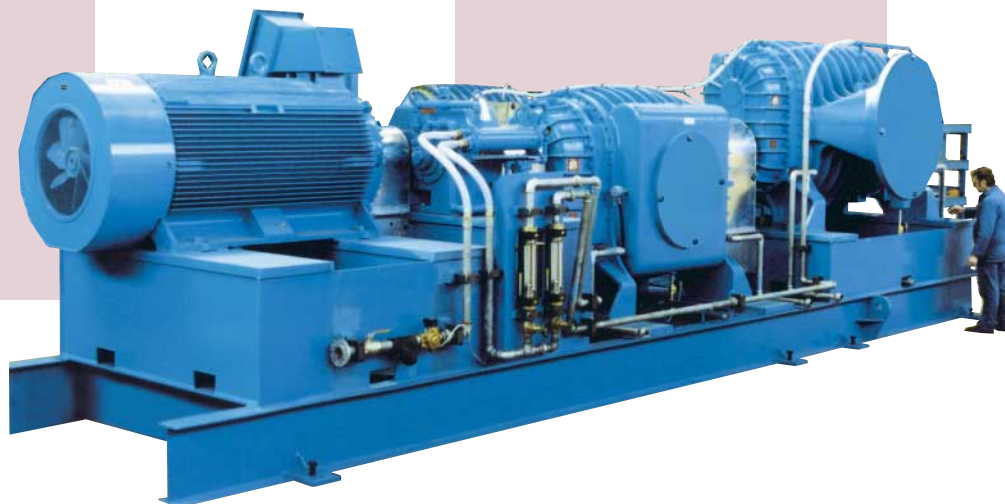

Customer Services

At DRESSER Roots we provide a complete range of services geared to keeping your Roots equipment operating at peak efficiency, and stopping unnecessary downtime.

Installation & Commissioning Our comprehensive aftermarket support includes installation and commissioning supervision for all packaged blower and vacuum pump units.

Repairs Blower repairs can be carried out in any of the four DRESSER Roots in-house repair facilities in the USA, UK or the Netherlands, or by one of our ten world-wide authorised service and repair facilities.

Spare Parts Spares are generally available for blowers & vacuum pumps on an ex-stock basis.

Testing All DRESSER Roots blowers and vacuum pumps are factory tested prior to shipment. Tests can include full package unit performance tests to recognised international standards.

Quality The DRESSER Roots manufacturing facilities in the USA and UK are fully ISO 9001 certified and follow Total Quality Management procedures.



▲ The new 20,000 sq. ft. Roots service centre in Houston, Texas.



▲ Blower repair work.



▲ A new variable speed model XLP test rig.

The original **ROOTS** blower™



Roots

PO BOX B7, Off St Andrews Road, Huddersfield HD1 6RB England.
Tel: +44 (0) 1484 42 22 22 Fax: +44 (0) 1484 42 34 29

E-mail: dmd.roots@dresser.co.uk
www.rootsblower.com

DRESSER, Inc.