



GE continues a history of innovation and technical leadership with it's Roots* Centrifugal Compressors



imagination at work



GE Energy is a global leader in the design and manufacture of air and gas handling solutions. As a trusted partner to the many industries it serves, GE leverages its history of technical innovation to address key environmental issues and to provide the technology exchange from its product engineering to customers around the globe.

For Reliability

Finite Element Analysis (FEA) and an extensive history in compressor design will assure that we provide you with a reliable solution that will last well into the future.



For Performance

Computational Fluid Dynamics (CFD) ensures each compressor is optimized to give you the best performance and efficiency possible, reducing your power requirements and minimizing the cost over the operating life of the compressor.



For Function

Working hand-in-hand with your engineers, we will establish a design that can be adopted into your process. Solid (3D) modeling aids in visualizing the compressor's layout and optimizing the footprint while proving fit and function.

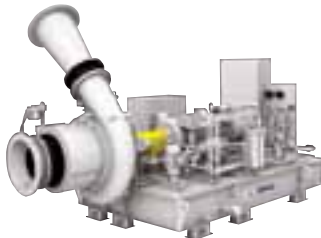

For You

Our design and application engineers will evaluate your given conditions and specifications to determine our unique solution that will perform and comply to your specific needs.



Designed for top performance and minimal maintenance

IMPELLERS: Offered in many different designs and constructions of several different materials, depending upon the operating conditions and gas being handled. The impeller is statically and dynamically balanced and then oversped to 15% above maximum operating speed. The impeller is then mounted on the shaft with a suitable locking device and the rotor assembly is dynamically balanced.



Multi-Stage Rotor Assembly



Open Wheeled Rotor Assembly



Closed Wheeled Rotor Assembly

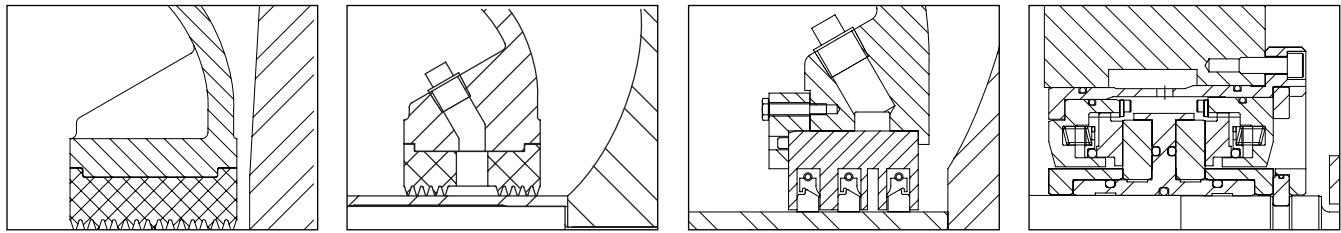
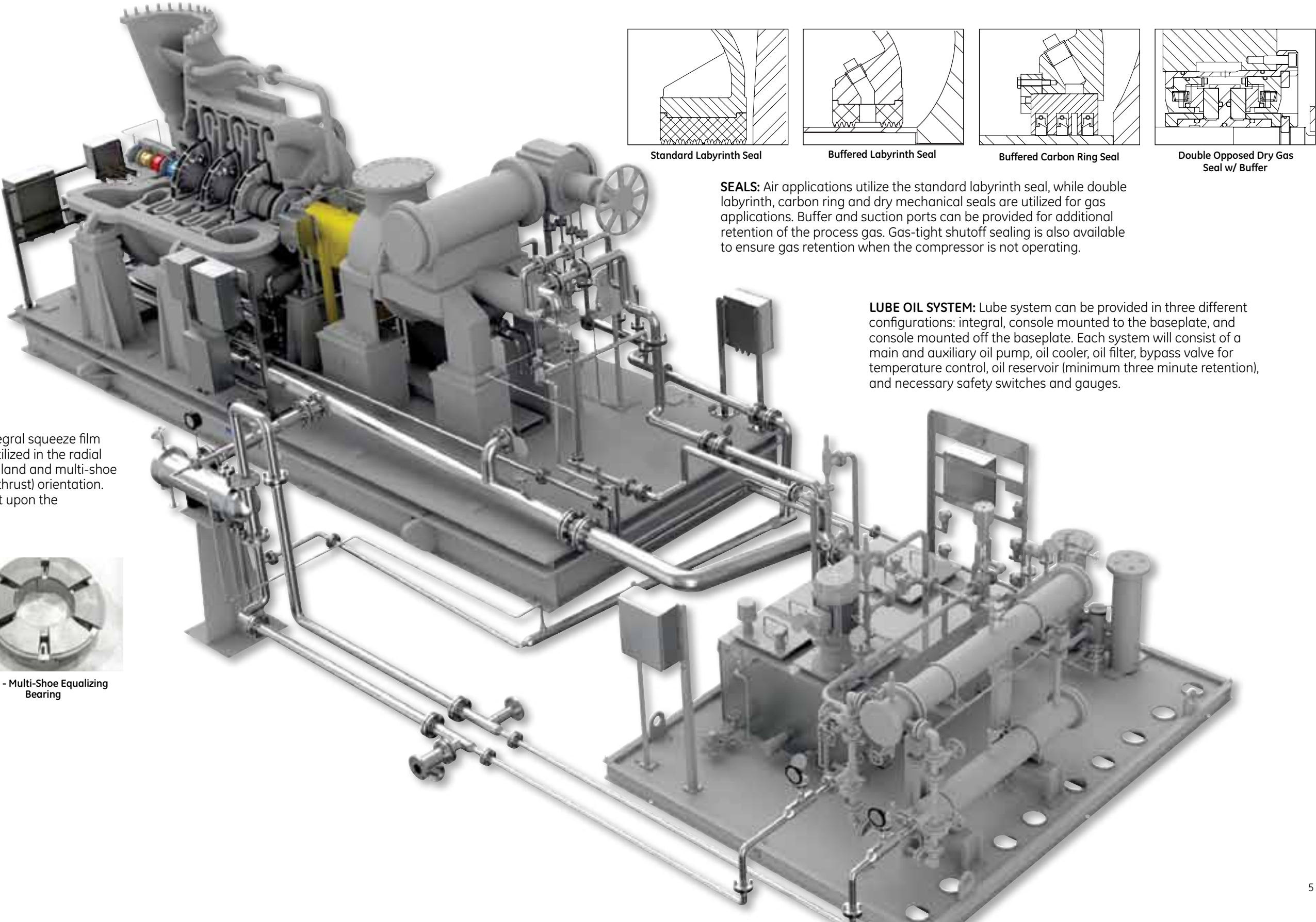

Standard Labyrinth Seal

Buffered Labyrinth Seal

Buffered Carbon Ring Seal

Double Opposed Dry Gas Seal w/ Buffer

SEALS: Air applications utilize the standard labyrinth seal, while double labyrinth, carbon ring and dry mechanical seals are utilized for gas applications. Buffer and suction ports can be provided for additional retention of the process gas. Gas-tight shutoff sealing is also available to ensure gas retention when the compressor is not operating.

LUBE OIL SYSTEM: Lube system can be provided in three different configurations: integral, console mounted to the baseplate, and console mounted off the baseplate. Each system will consist of a main and auxiliary oil pump, oil cooler, oil filter, bypass valve for temperature control, oil reservoir (minimum three minute retention), and necessary safety switches and gauges.

BEARINGS: Tilt pad, sleeve and integral squeeze film Damper (ISFD) type bearings are utilized in the radial (journal) orientation, while tapered land and multi-shoe equalizing are utilized in the axial (thrust) orientation. Bearing type is selected dependent upon the compressor type.



Radial - Tilt Pad Bearing



Axial - Multi-Shoe Equalizing Bearing

Roots IGCH Compressor

Integrally Geared Dual Vane

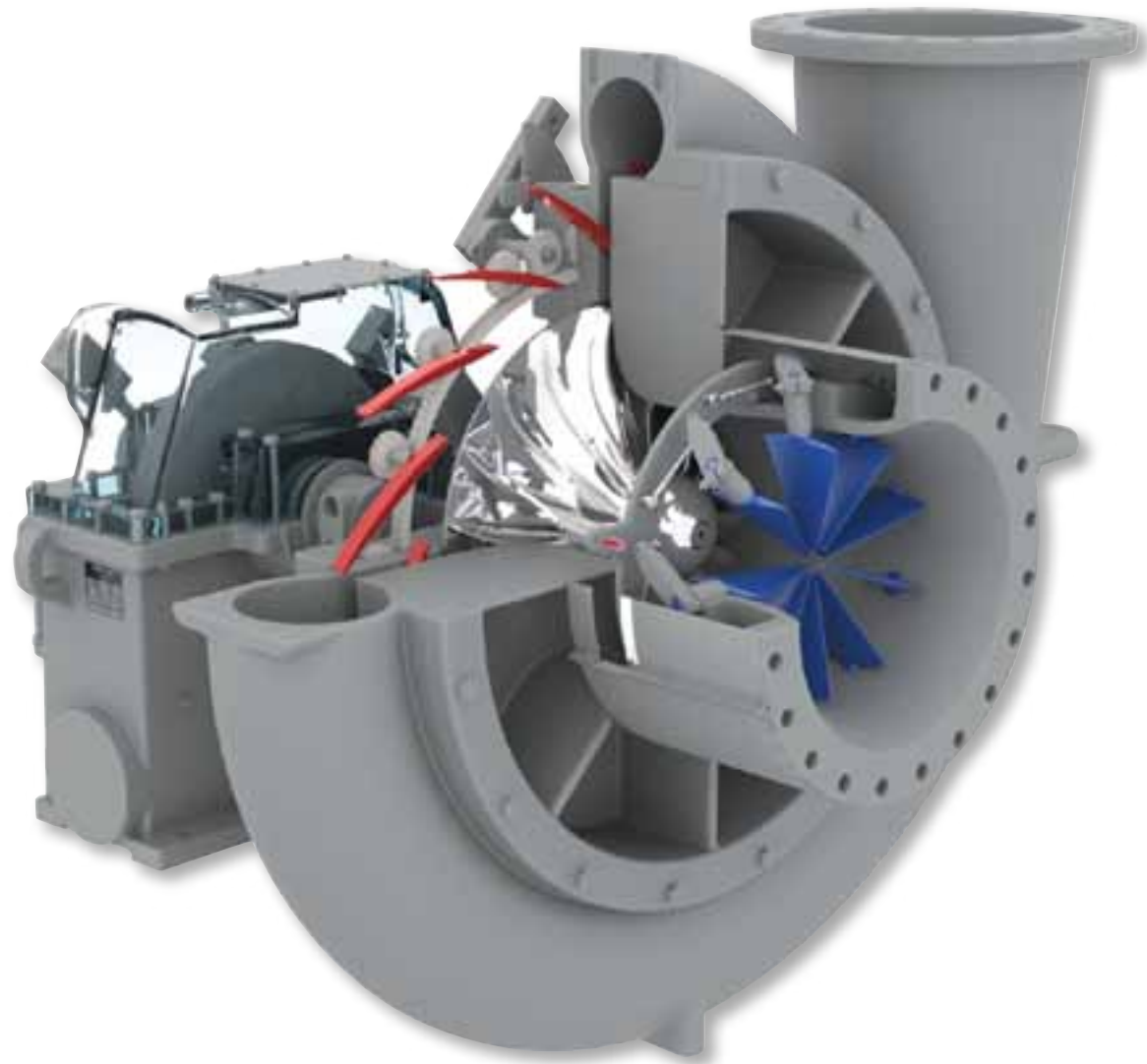

Roots IGCH Compressor Performance Map

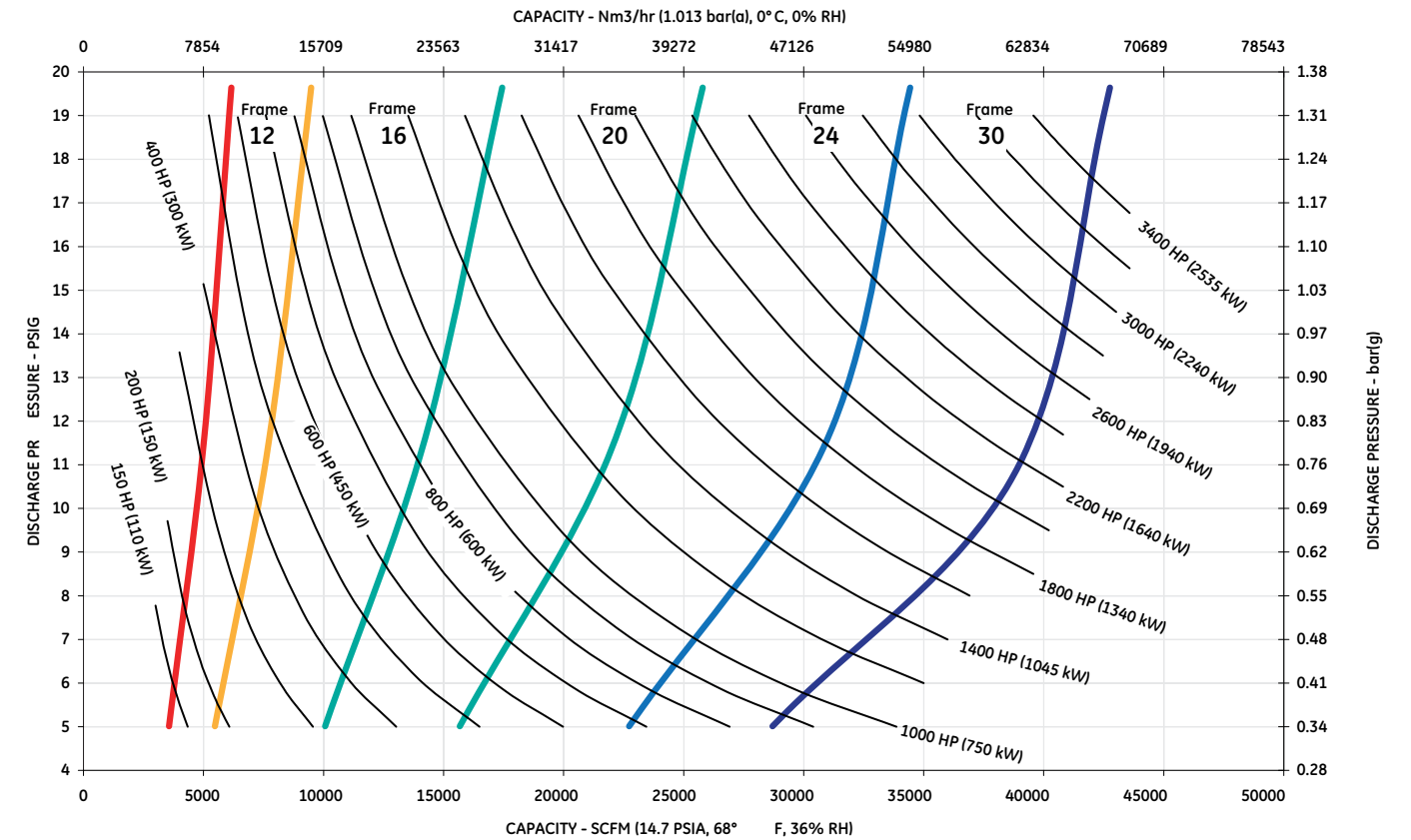

Gas Composition: Ambient Air
 Inlet Conditions: AIR, 14.5 PSIA, 100° F, 80% RH (1.00 bar(a), 38° C, 80% RH)
 Barometer: 14.7 PSIA (1.013 bar(a))

Characteristic	Value
Flow, SCFM (Nm ³ /hr)	4,000 to 42,000 (6,280 to 65,980)
Polytropic Head, ft*lb/lbm (kJ/kg)	10,000 to 40,000 (29.9 to 119.5)
Casing Materials	Cast iron, ductile iron (special materials available upon request)
Impeller Materials	Carbon steel, stainless steel, titanium
Impeller Construction	Radial, semi-backward leaning and backward leaning blades (open or closed); Cast, welded, milled
Discharge Position	45° increments, starting at 0° (UP) position
Spec. Compliance	API 617, API 672
Seal Arrangement	Labyrinth, carbon ring, mechanical
Vanes	Variable or fixed diffusers with variable axial inlet guide or variable peripheral inlet guide
Bearing Type	Journals: tilt pad & sleeve; thrust: tapered land



Variable Diffuser Vanes (VDV's) shown in minimum to maximum position. Roots' control system will independently modulate both the IGV's and VDV's to optimize the performance point as process conditions vary.



Roots IGCH Compressor Dimension Table

Unit Size	A* inches (mm)		B* inches (mm)	C inches (mm)	D inches (mm)	E inches (mm)	Weight lbs (kgs)
	MIGV'S**	MPGV'S**					
12" IGCH	12 (300)	N/A	12 (300)	170 (4300)	84 (2130)	65 (1650)	20,000 (9,070)
16" IGCH	16 (400)	20 (500)	16 (400)	185 (4700)	84 (2130)	70 (1780)	26,000 (11,800)
20" IGCH	20 (500)	24 (600)	20 (500)	200 (5080)	84 (2130)	73 (1850)	33,500 (15,200)
24" IGCH	24 (600)	30 (750)	24 (600)	220 (5600)	84 (2130)	84 (2130)	42,000 (19,050)
30" IGCH	30 (750)	36 (900)	30 (750)	230 (5840)	108 (2740)	95 (2410)	54,000 (24,500)

*Flanges are rated at 25# (Typ.) and drilled per ANSI B16.5 & B16.47A.

** MIGV'S - Movable Inlet Guide Vanes; MPGV'S - Movable Peripheral Inlet Guide Vanes

Name	Description
Compressor/Gear Box	Assembly incorporating a centrifugal compressor (rotor assembly, inlet housing, volute, casing cover, and bearing stand) and a speed increasing gear box in one housing. The compressor design is capable of facilitating the use of both inlet guide vanes as well as diffuser vanes (variable or fixed) for optimal efficiency over a wide range of performance points. Capable of meeting API-672 and API-617.
Driver	Primary drive options are electric motors, with or without variable frequency drive, and steam turbines. In select instances internal combustion (IC) engines have been utilized.
Lube Oil System	The standard IGCH design lends itself to the use of an integral lube system; in which the lube oil reservoir is housed within the structure of the baseplate, with the lube oil components (pumps, valves, coolers, and filters) mounted on top of the reservoir with the compressor. If specified, the lube system can be a separate console shipped loose for installation near the compressor. Lube systems can be designed to meet API-614 Chapters 2 or 3, as well as API-672.
Baseplate	Boxed construction utilizing structural supports for bracing and rigidity. Grouting pockets, anchor bolt holes and leveling screws are incorporated into the design to provide additional stability and rigidity during operation. Lifting lugs are incorporated into the design for ease in transportation of the equipment from the factory to the job site. Compressors can additionally be supplied with a drip lip and/or non-skid decking.
Controls	Provide conditional monitoring for the compressor, driver and lube oil system. Additionally, the local control panel (baseplate or off mounted) houses the intelligence for positioning inlet guide vanes and variable discharge diffuser vanes. The local instrumentation and panel provide real-time, local data through gauges, switches, or transmitters.

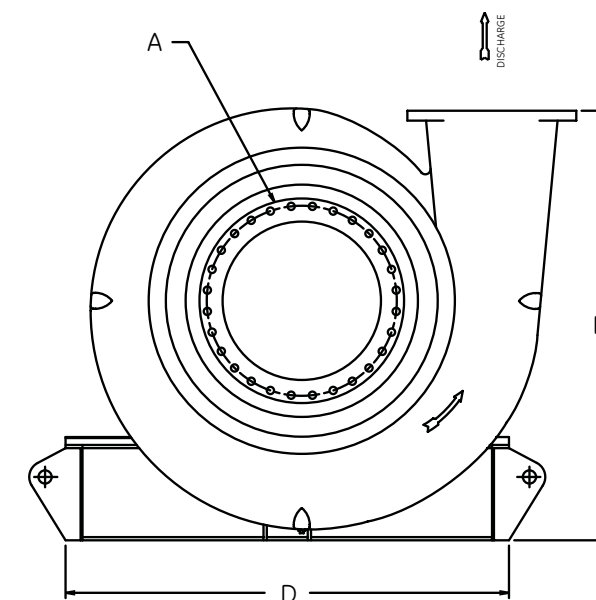
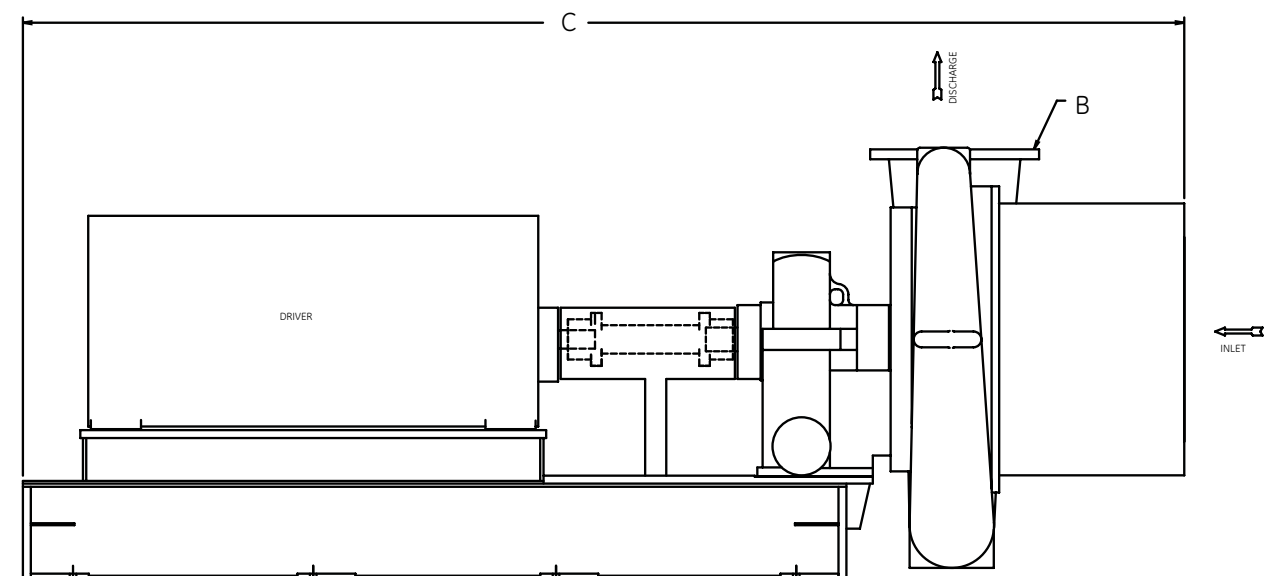

Roots OIB Compressor



Roots OIB Compressor Map

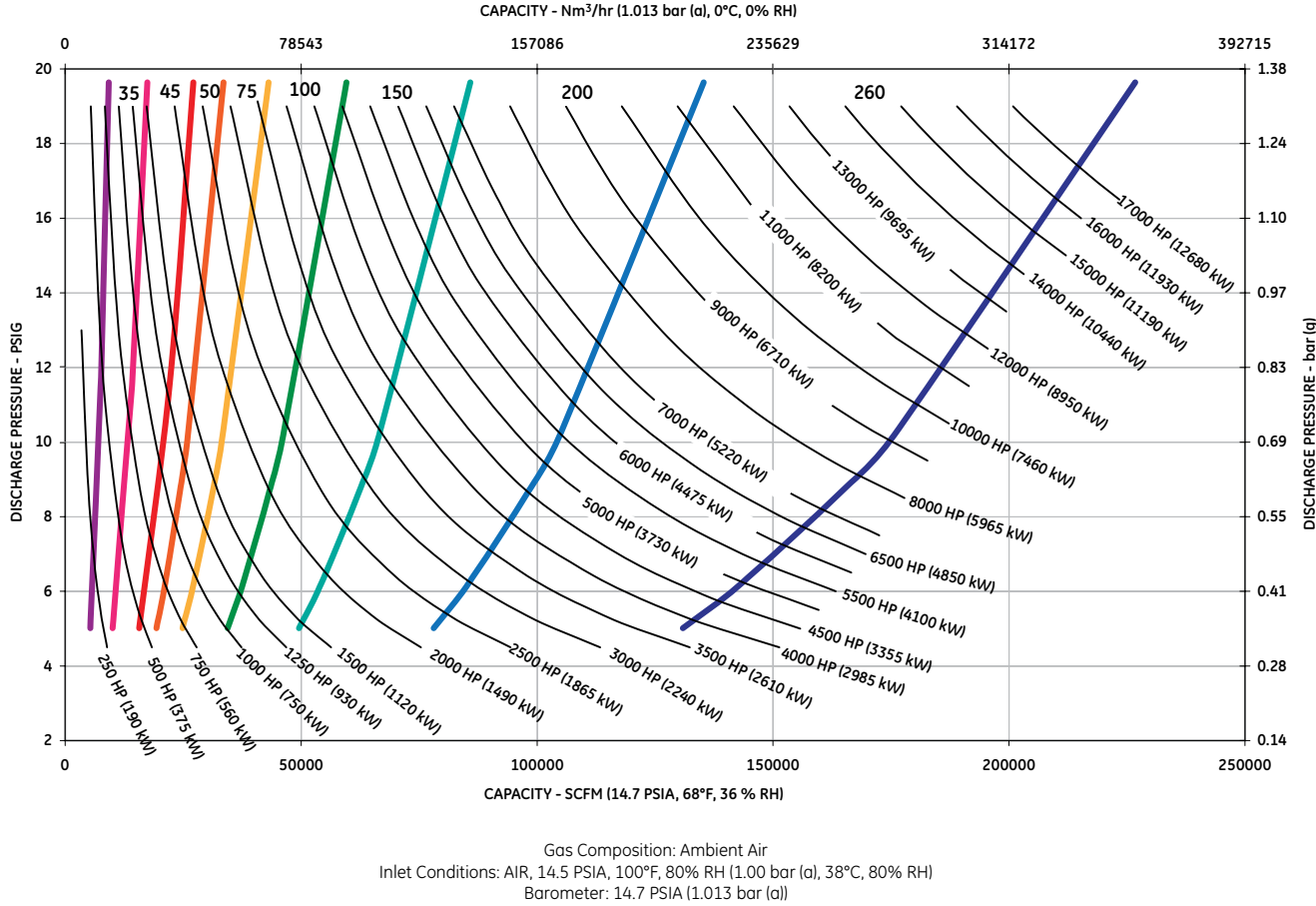

Characteristic	Value
Flow, SCFM (Nm ³ /hr)	5,000 to 225,000 (7,850 to 353,440)
Polytropic Head, ft*lb/ft ³ (kJ/kg)	10,000 to 40,000 (29.9 to 119.5)
Casing Materials	Cast iron, ductile iron (special materials available upon request)
Impeller Materials	Carbon steel, stainless steel, titanium
Impeller Construction	Radial, semi-backward leaning and backward leaning blades (open or closed); cast, welded, milled
Discharge Position	45° increments, starting at 0° (UP) position
Spec. Compliance	API 617
Seal Arrangement	Labyrinth, carbon ring, mechanical
Variable Vanes	Variable axial inlet guide or variable peripheral inlet guide
Bearing Type	Journal: tilt pad; thrust: multi-shoe equalizing



OIB Compressor with variable inlet guide vanes and open impeller



OIB Compressor with variable peripheral inlet guide vanes and closed impeller



Name	Description
Compressor	Overhung style centrifugal compressor consisting of a rotor assembly, inlet housing, volute, casing cover, and bearing stand. Optional inlet guide vanes allow for process control in the absence of a variable speed drive or inlet throttling valve. Capable of meeting API-617.
Gear Box	Speed increasing gear box designed to increase the driver input speed up to the rated compressor speed. The low speed shaft can incorporate the main oil pump of the lube system, when required. Compressor may also be supplied without gear box if driver can meet the rated compressor speed and power. Capable of meeting API-613.
Driver	Primary drive options are electric motors, with or without variable frequency drive, and steam turbines. In select instances internal combustion (IC) engines have been utilized.
Lube Oil System	There are three main options for the compressor lube system. First, an integral lube system; in which the lube oil reservoir is housed within the structure of the baseplate, with the lube oil components (pumps, valves, coolers, and filters) mounted on top of the reservoir with the compressor. Second, a console lube system, with separate reservoir, mounted to the baseplate frame. Lastly, the lube system can be a separate console shipped loose for installation near the compressor. Lube systems can be designed to meet API-614 Chapters 2 or 3.
Baseplate	Boxed construction utilizing structural supports for bracing and rigidity. Grouting pockets, anchor bolt holes and leveling screws are incorporated into the design to provide additional stability and rigidity during operation. Lifting lugs are incorporated into the design for ease in transportation of the equipment from the factory to the job site. Compressors can additionally be supplied with a drip lip and/or non-skid decking.
Controls	Provide conditional monitoring for the compressor, driver and lube oil system. Additionally, the local control panel (baseplate or off mounted) houses the intelligence for positioning inlet guide vanes. The local instrumentation and panel provide real-time, local data through gauges, switches, or transmitters.

Roots OIB Compressor Dimension Table

Unit Size	A* inches (mm)		B* inches (mm)	C inches (mm)	D inches (mm)	E inches (mm)	Weight lbs (kgs)
	W/ IGV'S	W/O IGV'S					
OIB-35	16 (400)	16 (400)	16 (400)	200 (5080)	72 (1830)	78 (1980)	30,000 (13,600)
OIB-45	20 (500)	20 (500)	20 (500)	210 (5330)	84 (2130)	78 (1980)	40,000 (18,150)
OIB-50	18 (450)	20 (500)	16 (400)	220 (5600)	96 (2440)	78 (1980)	40,000 (18,150)
OIB-75	24 (600)	22 (550)	18 (450)	220 (5600)	114 (2900)	81 (2060)	42,000 (19,050)
OIB-100	24 (600)	24 (600)	22 (550)	250 (6350)	90 (2290)	85 (2160)	45,000 (20,400)
OIB-150	39 (900)	36 (900)	30 (750)	290 (7360)	96 (2440)	110 (2790)	70,000 (31,750)
OIB-200	36 (900)	36 (900)	30 (750)	300 (7620)	108 (2740)	96 (2440)	95,000 (43,100)
OIB-260	50 (1270)	50 (1270)	42 (1070)	350 (8890)	120 (3050)	107 (2720)	125,000 (56,700)

* Flanges are rated at 25# (Typ.) and drilled per ANSI B16.5 & B16.47A
 ** IGV'S - Inlet Guide Vanes

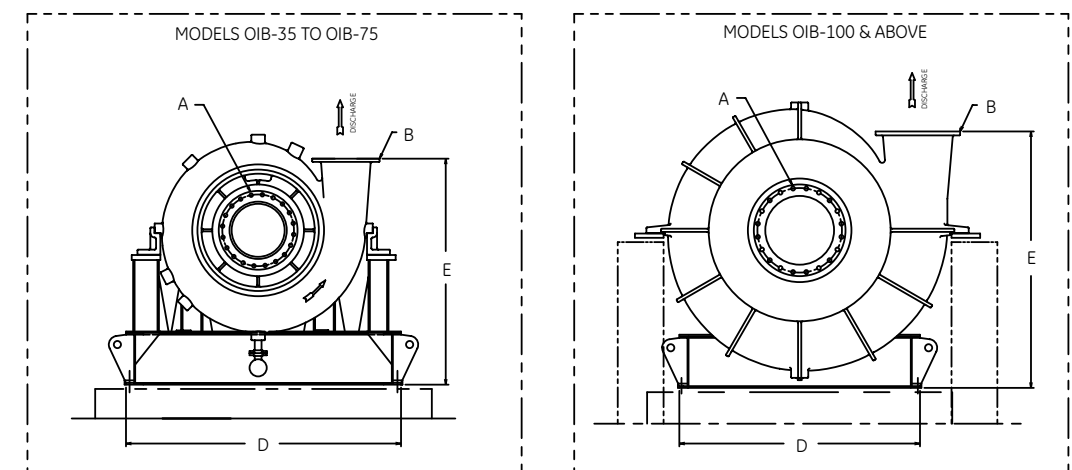
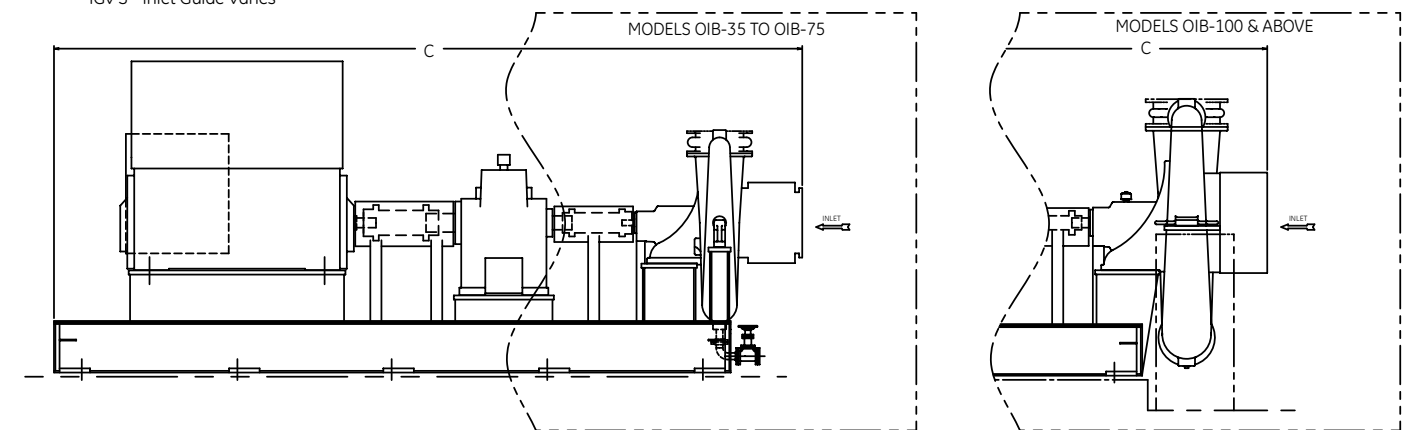

Roots Type H

Horizontally-Split Multi-Stage Compressor

Roots H-Multi Stage Compressor Map

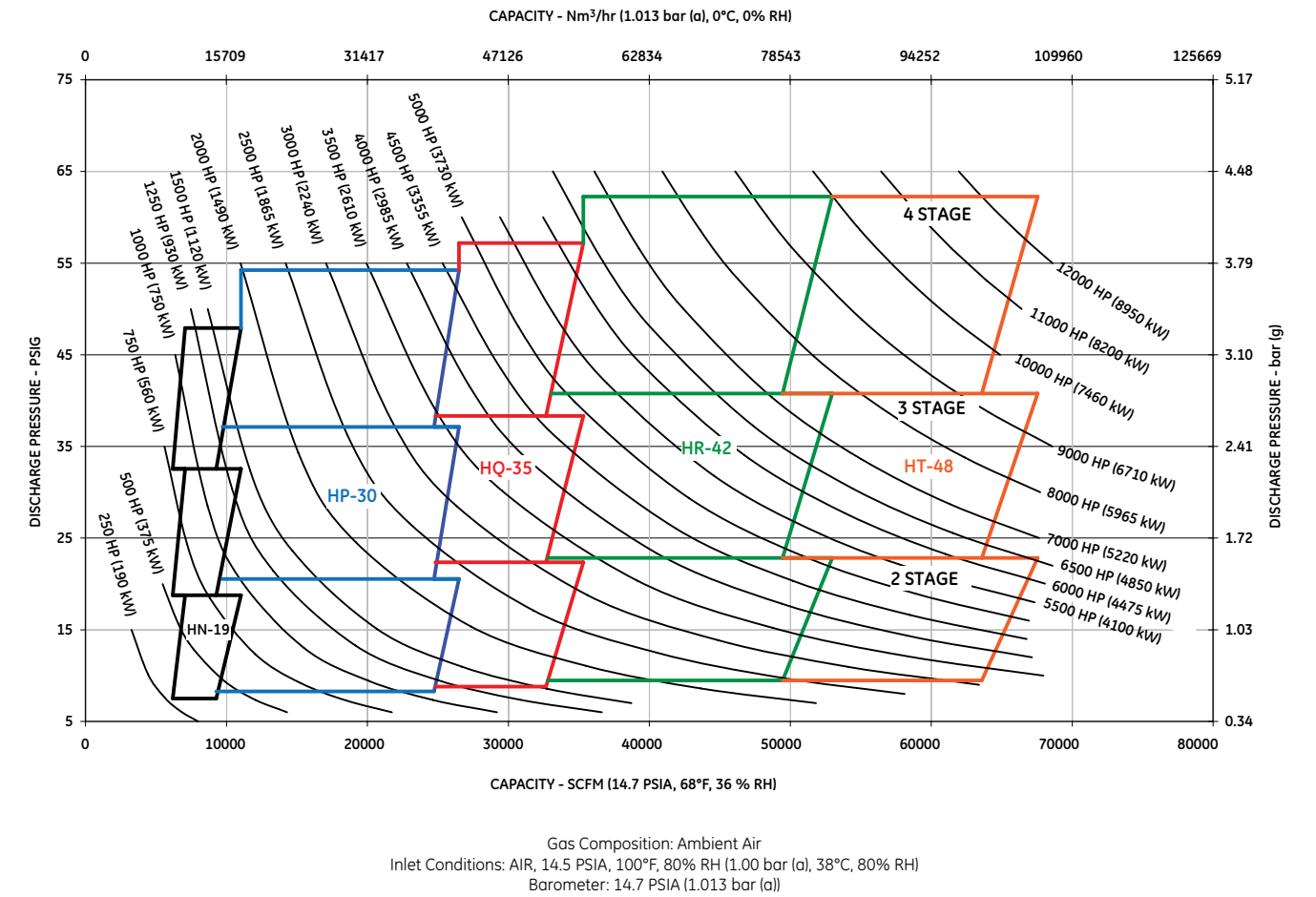

Characteristic	Value
Flow, SCFM (Nm ³ /hr)	6,000 to 67,000 (9,430 to 105,250)
Polytropic Head, ft*lb/ft ³ (kJ/kg)	14,000 to 65,000 (41.8 to 194.3)
Casing Materials	Cast iron, ductile iron (special materials available upon request)
Impeller Materials	Carbon steel, stainless steel
Impeller Construction	Semi-backward leaning and backward leaning blades (closed); welded or milled & welded
Spec. Compliance	API 617
Seal Arrangement	Labyrinth, carbon ring, mechanical
Vanes	Variable or fixed inlet guide vanes
Bearing Type	Journal: tilt pad; thrust: multi-shoe equalizing
Compressor Stages	2, 3, 4 (specialty staging available)

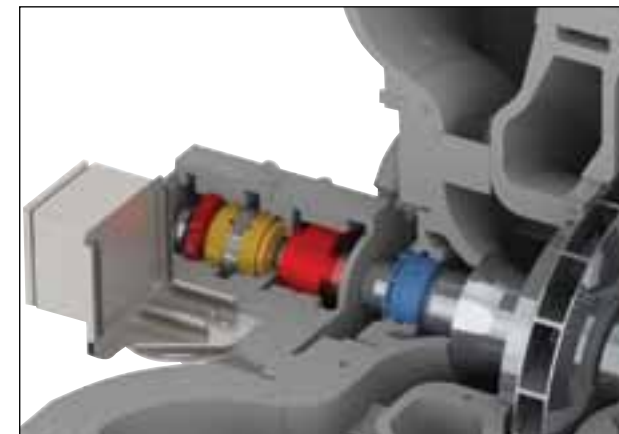

H Multi-Stage bearing and seal housing



H Multi-Stage casing with inter-stage diaphragms and rotor assembly



Name	Description
Compressor	Horizontally split centrifugal compressor consisting of top and bottom casing halves, rotor assembly, inter-stage diaphragms, seals, and bearing stands. Inlet section is capable of housing fixed or variable guide vanes for flow conditioning/ process control. Adaptable for up or down inlet and discharge connection orientations. Capable of meeting API-617.
Driver	Primary drive options are electric motors, with or without variable frequency drive, and steam turbines. In select instances internal combustion (IC) engines have been utilized. A separate speed increasing gear box can be included if needed for performance.
Lube Oil System	There are three main options for the compressor lube system. First, an integral lube system; in which the lube oil reservoir is housed within the structure of the baseplate, with the lube oil components (pumps, valves, coolers, and filters) mounted on top of the reservoir with the compressor. Second, a console lube system, with separate reservoir, mounted to the baseplate frame. Lastly, the lube system can be a separate console shipped loose for installation near the compressor. Lube systems can be designed to meet API-614 Chapters 2 or 3.
Baseplate	Boxed construction utilizing structural supports for bracing and rigidity. Grouting pockets, anchor bolt holes and leveling screws are incorporated into the design to provide additional stability and rigidity during operation. Lifting lugs are incorporated into the design for ease in transportation of the equipment from the factory to the job site. Compressors can additionally be supplied with a drip lip and/or non-skid decking.
Controls	Provide conditional monitoring for the compressor, driver and lube oil system. Additionally, the local control panel (baseplate or off mounted) houses the intelligence for positioning inlet guide vanes. The local instrumentation and panel provide real-time, local data through gauges, switches, or transmitters.

Roots Type H Multi-Stage Dimensional Table

Unit Size	A* inches (mm)	B* inches (mm)	C** inches (mm)	D inches (mm)	E inches (mm)	Weight lbs (Kgs)
HN	18 (450)	14 (350)	192 (4880)	72 (1830)	78 (1980)	35,000 (15,875)
HP	30 (750)	24 (600)	220 (5600)	102 (2590)	98 (2490)	71,500 (32,430)
HQ	36 (900)	24 (600)	240 (6100)	108 (2740)	120 (3050)	78,000 (35,380)
HR	42 (1050)	24 (600)	250 (6350)	120 (3050)	132 (3350)	92,000 (41,730)
HT	48 (1200)	36 (900)	260 (6600)	138 (3500)	150 (3810)	130,000 (58,970)

*Flanges are rated at 25# (Typ.) and drilled per ANSI B16.5 & B16.47A

**Total length is subject to change based on number of stages or the need for a gear box

NOTE: Inlet and Discharge of Compressor may be oriented in either the top or bottom direction, or any combination of the two.

NOTE: Compressor may be driven through Inlet or Discharge End.

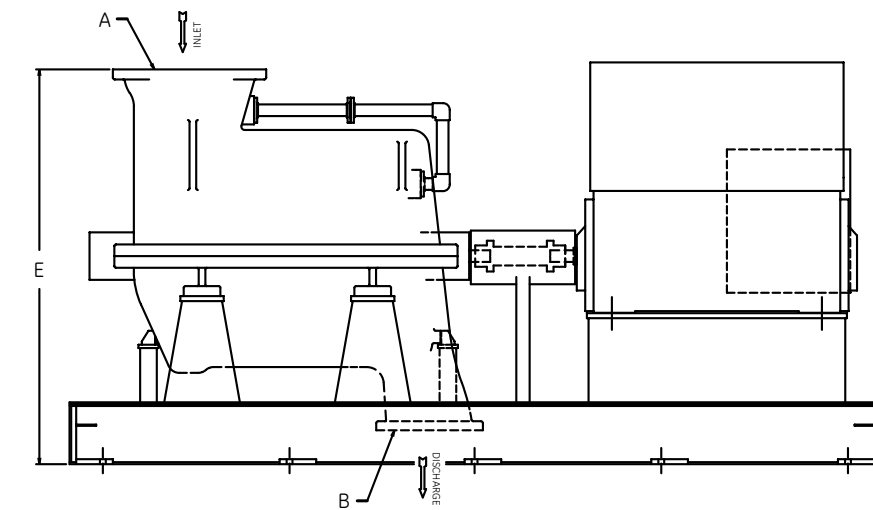
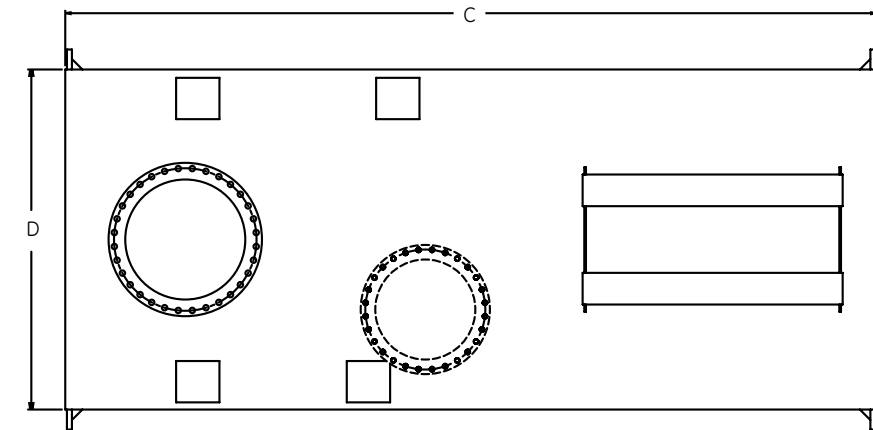

Control Solutions Specific to Your Application

Instrumentation and Control

- Inlet guide vane and variable diffuser vane control
- Compressor conditional monitoring:
 - Vibration/displacement
 - Temperature
 - Pressure
 - Speed
- Active compressor surge control system, ensuring continual operation of your compressor.
- Application specific control algorithms
- Digital and/or analog compressor instrumentation panel
- NEMA 4, 4X and 12 electrical enclosure options



Roots Wastewater Controls

- Save 25% to 40% of your energy costs, as compared to manual control
- Reduce consumption and demand charges
- Assistance in obtaining utility rebates
- Most open valve control to minimize system pressure
- Coordinate aeration demand and blower supply air flows

Technology Options

- IntelliView® process controller
- PLC's supported:
 - ABB
 - Allen Bradley/Rockwell Automation Co., Inc.
 - Siemens AG
 - Other major manufacturers
- Optional monitoring systems:
 - Bently Nevada
 - Compressor Controls Corporation (CCC)
 - IRD
 - Other major manufacturers



Manufacturing Expertise

The manufacturing methods and procedures at our 200,000 sq. ft. facility rely collectively on our highly skilled individuals and versatile machining.

Manufacturing Processes Includes:

- 5 - Axis CNC Milling
- 3 - Axis CNC Milling
- CNC Lathe Turning & Grinding
- Welding
- Pipe Fitting
- Balancing & Overspeed Test (Impellers)

Utilizing these individuals coupled with our passion for quality and drive for excellence, we can ensure that only world-class product is delivered to our customers each and every time.

Testing, Testing, Testing

Our compressor's components and assemblies are thoroughly tested to verify that material functionality and properties are compliant to our design and your specification.

Tests include:

- Hydrostatic pressure (casing)
- Blade frequency (impeller)
- Overspeed (impeller)
- Mechanical run (compressor)
- Performance test, per ASME PTC-10
- Test points specified by customer

Test reports are provided to the customer upon completion of compressor testing.

All compressors are fully tested to meet customer requirements. Our 5,000 HP (3,725 kW) variable speed drive train, indoor testing beds and data acquisition software are utilized to test your compressor under full load conditions. For compressors with higher power ratings, tests can be performed using the customer/job motor or testing the compressor as an exhaustor to verify performance.



Service and Repair Warranties

GE Energy backs all maintenance and repair work performed at GE facilities or in the field.

- One year parts and workmanship including competitor's parts
- Competitive pricing

ISO-9001 and ISO-14000 Certified-
Houston, TX, & Connersville, IN

Superior Field Services

- Full job-site troubleshooting services and capabilities
- Vibration & noise analysis
- Alignment (all major components)
- Job-site repair and replacement
 - Bearings
 - Seals
 - Rotating assemblies
 - Couplings
- 24 to 48-hour emergency services response for most areas

Global Aftermarket Coverage

GE Energy maintenance and repair services provide professional methods and procedures that restore proper functionality and performance to each repaired unit. Access to GE factory repair and service is available around the world. See the back cover for your nearest location. Service for small rotary blowers is available through our network of authorized distributor repair centers which can be searched on our website. All authorized repair centers use authentic Roots parts to assure warranty compliance.

Unmatched Experience

We have extensive experience in the repair and maintenance of all brands of vacuum blowers and exhaustors, blowers, and centrifugal compressors. Our capabilities allow us to repair or remanufacture all of your equipment to original or higher specifications.

GE Energy

Houston, Texas USA Headquarters • U.S. Toll Free Phone: 1 877-363-ROOT(S) (7668) • Direct Phone: +1 832-590-2600

Connersville, Indiana USA Operations • U.S. Toll Free Phone: 1 877-442-7910 • Direct Phone: +1 765-827-9285

Connersville, Indiana USA Factory Service • Phone +1 765-827-9306

Houston, Texas USA Factory Service • Phone: +1 713-896-4810

Waukesha, Wisconsin USA Operations • Direct Phone: +1 262-650-5965

USA/Canada Sales (Chicago Illinois) • Phone: +1 847-631-9741

Mexico City, Mexico Sales and Factory Service • Phone: +52 55 5889 5811

Skelmersdale, United Kingdom Operations • Phone: +44 (0) 1695 52600

Dubai, UAE Sales and Factory Service • Phone: +971 4 8855481/8991777

Saudi Arabia (Kingdom of) Sales • Phone +966 (0) 535364477

Kuala Lumpur, Malaysia Sales • Phone: +60 3 2267 2600

Beijing, China Sales • Phone: +86 10 8486 2440

Shanghai, China Operations • Phone: +86 21 5858 7638

Seoul, Korea (Republic of) Sales • Phone +82 2 2274 0771

Visit us online at:

www.ge.com/energy

2011 General Electric Company

All Rights Reserved

